

**601e & 301e
Mic/Line Mixers**

Operation Manual

advantage ®

TABLE OF CONTENTS

Front Panel	pg. 2
Rear Panel	pg. 3
Modifications/Accessories	pgs. 4 & 5
Applications	pgs. 6~9
Block Diagram	pg. 10
Specifications	pg. 11
Warranty	

INTRODUCTION

The Advantage **601e** & **301e** are single rack space, six input & three input mic/line mixers. Each input channel uses a differentially balanced, discrete transistor mic/line preamplifier for low noise and low distortion performance. Inputs are provided to accept signals from microphones and/or line level devices, as well as an input for devices, such as telephone lines, which require 600 Ω transformer isolation. Special features, including limiters and remote level control, make the **601e** & **301e** extremely versatile. Advantage **601e** & **301e** mixers are dependable, easy to install, simple to operate, and are covered by an Advantage Five-Year "Gold Seal" Warranty.

Advantage **601e** & **301e** features include:

- ◆ five electronic balanced mic/line input channels (**601e**)
- ◆ two electronic balanced mic/line input channels (**301e**)
- ◆ one transformer balanced 600 Ω line input channel (internal jumpers for standard mic/line option)
- ◆ 30dB rear panel Pad switch on each input channel
- ◆ 40dB screwdriver-adjust Trim on each input channel
- ◆ +10dB Peak LED indicator on each input channel
- ◆ rotary level control on each input channel
- ◆ optional input isolation transformers (user installed)
- ◆ auto-muting of one channel for "page-over" applications (triggering from other channels via internal jumpers)
- ◆ +12 volt Phantom Power for condenser microphones (internal jumpers select channels and +48 volt option)
- ◆ electronic balanced main output with rotary level control
- ◆ remote control of main level from up to 2000 feet away
- ◆ main patch insert point for external processing devices
- ◆ main stacking input accepts signals from other mixers
- ◆ limiter with screwdriver-adjust threshold & LED indicator
- ◆ screwdriver-adjust Treble & Bass main tone controls
- ◆ -20dB Signal Present LED indicator for main output
- ◆ all connections on barrier strip screw terminals
- ◆ covered by Advantage Five-Year "Gold Seal" Warranty
- ◆ UL listed power source

After reading this manual, if you have any questions or need technical assistance, please call Biamp Systems toll-free (1-800-826-1457).

FRONT PANEL

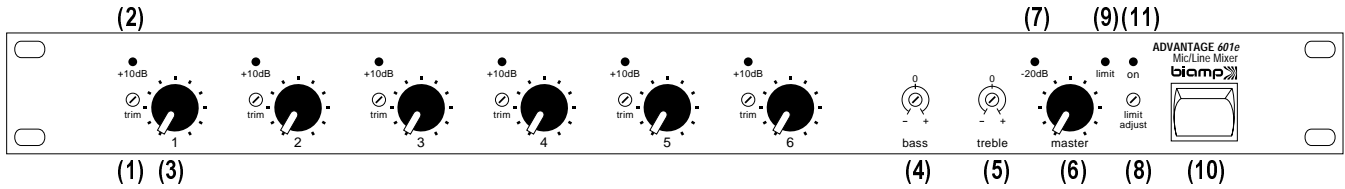

(1) Trim: These screwdriver adjustable controls provide 40dB of gain adjustment to compensate for different input signal levels. For best performance, adjust Trim so the Peak Indicator (2) flashes only on occasional peaks in signal level (see Rear Panel: Pad on page 3).

(2) +10dB (Peak Indicator): These red LEDs indicate signal level in the channel has reached +10dB (8dB below clipping). For best performance, adjust Trim so the Peak Indicator flashes only on occasional peaks in signal level (see Rear Panel: Pad on page 3).

(3) Level: These controls adjust the level of channel signal sent to the Main Output section. Level control settings will vary from channel to channel, depending upon the desired mix. However, for best performance, higher settings should center around the 12 o'clock position (unity gain). One of the channels includes a level "ducking" feature, which can be triggered when signal is present in selected other channels (see Modifications/Accessories: "Ducking" on page 5). This "ducking" feature is useful in page-over-music applications.

(4) Bass: This screwdriver-adjustable control sets the low-frequency equalization (Bass) for the Main Output section. Bass is a shelving type filter, which provides +/-10dB of gain adjustment for frequencies below 100Hz.

(5) Treble: This screwdriver-adjustable control sets the high-frequency equalization (Treble) for the Main Output section. Treble is a shelving type filter, which provides +/-10dB of gain adjustment for frequencies above 10kHz.

(6) Master Level: This control adjusts the overall level of signal sent to the Main Output (see Rear Panel: Main Output on page 3). The Master Level control is used to make adjustments in volume level. However, for best performance, higher settings should center around the 12 o'clock position (unity gain). Sound system amplifiers may then be set for the appropriate volume level. Main Output level can also be adjusted via remote control (see Rear Panel: Remote on page 3).

(7) -20dB (Signal Present Indicator): This red LED indicates signal level at the Main Output is above -20dB (normal signal level). Once the Master Level control has been adjusted, this indicator will remain lit whenever signal is present at the Main Output.

(8) Limit Adjust: A limiter is provided at the Main Output section to help eliminate unwanted peaks in program signal level. This screwdriver adjustable control sets the threshold level, at which the limiter is activated. For most applications, set this control so the Limit Indicator (9) is lit by occasional peaks in program signal level. Counter-clockwise adjustment lowers the threshold, increasing the amount of limiting. Clockwise adjustment raises the threshold, ultimately removing the limiter from operation. This control is factory set fully clockwise (limiter off).

(9) Limit Indicator: This red LED indicates when the limiter is activated by program signal levels that exceed the threshold setting.

(10) Power Switch: This switch turns the mixer on. If the Power Indicator (11) fails to light and the mixer does not pass signal properly, turn the mixer off and check power connections (and possibly another AC outlet). If the problem persists, the mixer may require service.

(11) On (Power Indicator): This red LED indicates when the Power Switch is turned on and power is applied to the mixer.

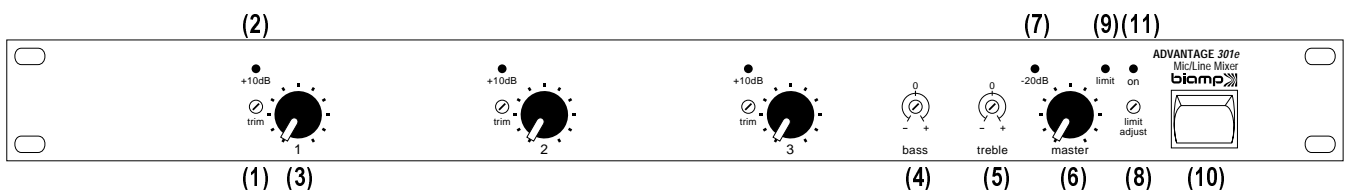

REAR PANEL

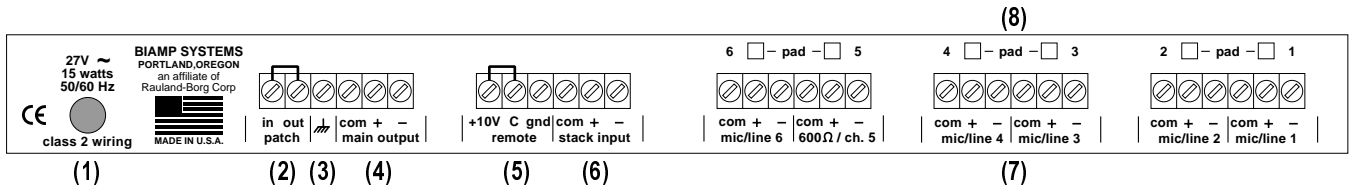

(1) AC Power Cord: The external power transformer provides 27 Volts AC to the mixer, and is detachable via a 5-pin DIN connector. The mixer has two internal 1 amp normal blow (1A NB) fuses. If these fuses should require replacement, use same value and type fuses only. An optional +48 Volt Phantom Power Supply may be inserted 'in-line' with the AC Power Cord (See Modifications/Accessories: +48 Volt Phantom Power Supply on page 5).

(2) Patch: These two terminals provide an insert point for connection of processing equipment to the Main Output section. Patch is post-Main EQ (Bass & Treble) and pre-Main Level. The OUT terminal provides a send to the input of an external device. The IN terminal provides a return from the output of the external device. Grounding for both connections is supplied by the COM terminal at Main Output (4). Remove the factory installed jumper strap between OUT and IN terminals only when Patch is in use. Patch may also be used to provide an unbalanced, pre-Main Level output. This is accomplished by using the Patch OUT terminal as the send, with grounding supplied by the Main Output COM terminal, and leaving the Patch IN/OUT jumper strap in place (removal of the jumper strap will interrupt signal sent to the Main Output).

(3) Chassis Ground: This terminal provides a chassis ground point, which is not provided by the external power transformer. In some situations, connection of this terminal to AC ground (and/or the Main Output COM terminal) may provide better grounding for the system.

(4) Main Output: These three terminals provide an electronically balanced Main Output from the mixer, wired with high to (+), low to (-), and ground to (COM). For unbalanced output, connect high to (+) and ground to (COM), leaving low (-) unconnected. Main Output signal is a combination of the various channel signals, as well as signal from Stack Input (7) and any signal processing applied at Patch. This output is for connection to the input of sound system amplifiers, tape recorders, etc.

(5) Remote: These three terminals allow remote control of the Main Output level. The remote controls can be potentiometers (for level adjustment) and/or switches (for muting). These controls may be wired up to 2000 feet from the mixer, using 2-conductor shielded cable. Potentiometers should be 5k~50k ohms (linear taper). Switches may be used alone, or with variable or fixed resistors, to provide on/off or muting. Main Output level is determined by the amount of control voltage at control terminal "C" (+10V = unity gain; 0V = -74dB). Remove the factory installed jumper only when connecting remote controls (see Modifications/Accessories: Remote Controls on page 5).

(6) Stack Input: These three terminals provide a line level input for signals from external devices, such as other mixers. Stack Input signal is combined with the channel signals, before being sent to the Main Output section. Connect balanced inputs with high to (+), low to (-), and ground to (COM). For unbalanced use, connect inputs with high to (+) and ground to both (-) & (COM)

(7) Inputs: These terminals provide input to the channels. Most inputs are electronically balanced and will accept either microphone or line level signals. However, one Input is assigned as a 600 ohm transformer balanced input, which will accept line level signals only (Channel 5 on model 601e and Channel 2 on model 301e). This Input may be re-assigned to accept either microphone or line level signals (see Modifications/Accessories: Mic/Line on page 5). Connect balanced inputs with high to (+), low to (-), and ground to (COM). For unbalanced use, connect inputs with high to (+) and ground to both (-) & (COM). Phantom Power (+12 Volts) is available internally, for operation of condenser microphones. If +48 Volts Phantom Power is required, an external power supply is available as an option. Input transformers are also available as an option. (For more information about Phantom Power and Input Transformers, see Modifications/Accessories on page 5.)

(8) Pad Switches: These switches reduce the channel input signal level by 30dB. Depress this switch when channel input signal levels exceed the normal operating range of the front panel Trim control.

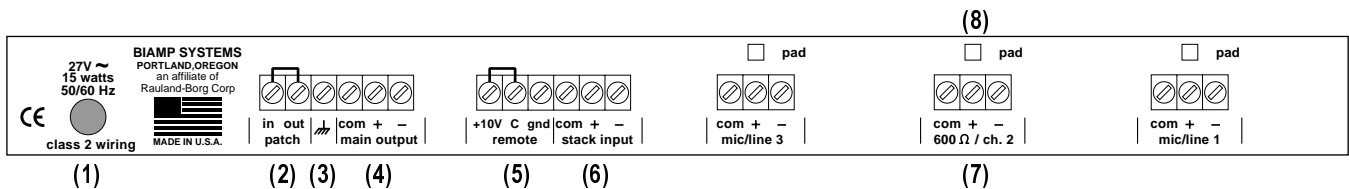

MODIFICATIONS/ACCESSORIES

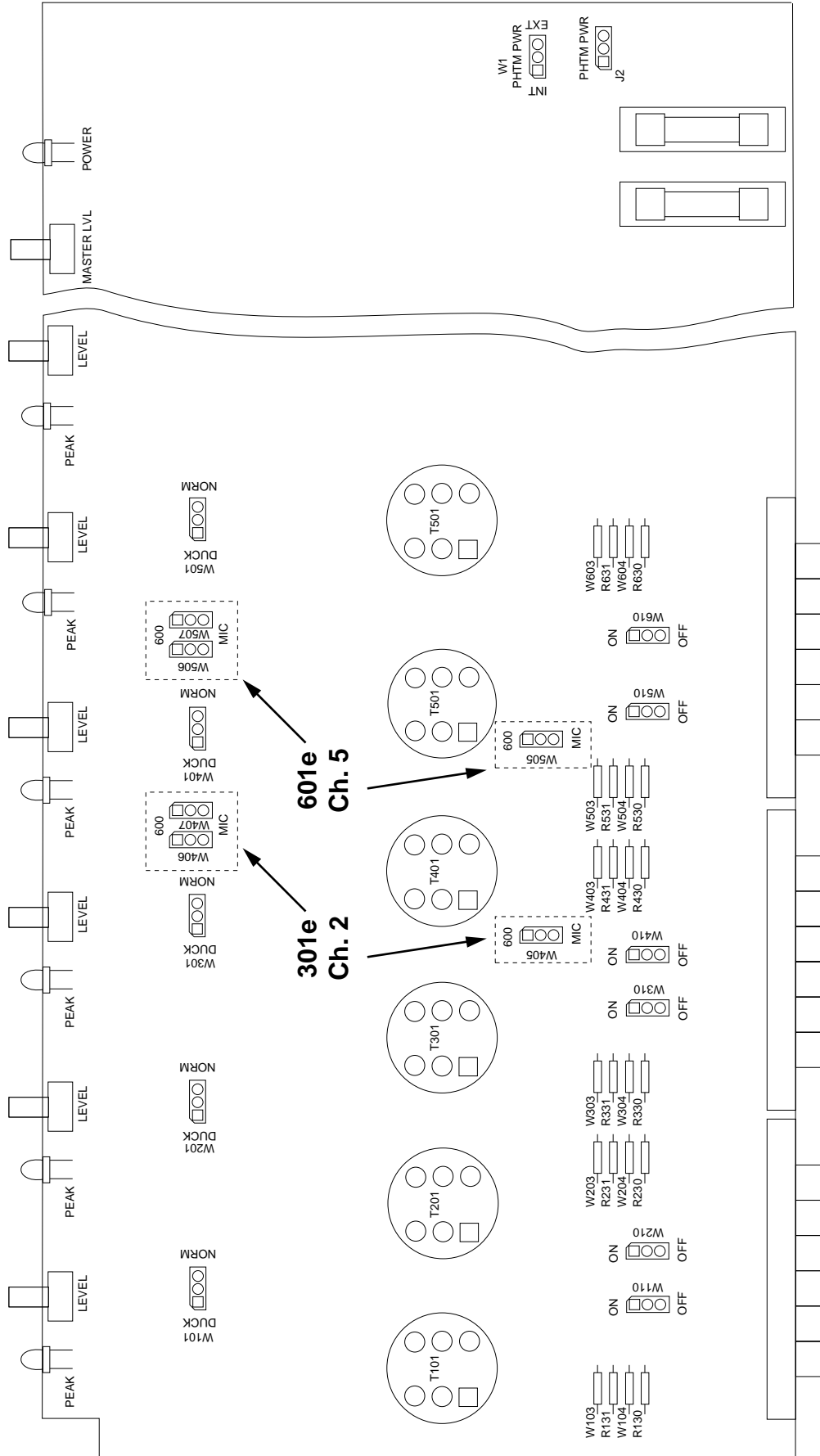

MODIFICATIONS/ACCESSORIES

NOTE: Disconnect the mixer from the AC outlet. Remove the bottom panel to access internal modifications only. The diagram on page 4 shows the printed circuit board (PCB) and components as they appear when the mixer is upside-down, with the front panel facing away.

+12 Volt Phantom Power: A movable jumper strap is provided for each channel. Any or all channels may be assigned Phantom Power by moving the respective jumpers (W110 for channel 1, W210 for channel 2, etc.) to the "ON" position (towards the front panel). Model 301e uses channel 2, 4, & 6 PCB positions (jumpers W210, W410, & W610). Internal Phantom Power is +12 Volts. An external +48 Volt Phantom Power supply is available as an option.

+48 Volt Phantom Power Supply: The internal +12 Volt Phantom Power of the Advantage 601e & 301e may not be sufficient power for some condenser microphones. When using condenser microphones that require +48 Volt Phantom Power, an external power supply may be added to convert Phantom Power to +48 Volts. To connect the external +48 Volt Phantom Power Supply: A) remove the detachable power transformer from the Advantage 601e/301e mixer by separating the 5-pin DIN connection in the AC Power Cord; B) insert the +48V Phantom Power Supply into the AC Power Cord (between the power transformer & the Advantage 601e/301e mixer) using the 5-pin DIN connectors provided; C) move jumper strap labelled "PHTM PWR" (W1) to the "EXT" position (towards the right), selecting "external" Phantom Power; D) assign Phantom Power to desired channels (see +12 Volt Phantom Power above). +48 Volt Phantom Power Supplies are available from Biamp Systems (#909-0012-00).

CAUTION: Do not assign Phantom Power to channels being used for line level or unbalanced inputs. To avoid possible damage to the sound system, always turn mixer off before making connections to channels with Phantom Power.

"Ducking": Movable jumper straps are provided on channels 1-5 (channels 1 & 2 on 301e) to allow signal present in those channels to cause channel 6 (channel 3 on 301e) to drop 15dB in level ("ducking"). When signal is no longer present in the selected channels, then level in the "ducking" channel will gradually return to normal. This is useful for "page-over-music" applications. Any or all of the non-"ducking" channels may be selected to trigger the "ducking" channel, by moving the respective jumpers (W101 for channel 1, W201 for channel 2, etc.) to the "DUCK" position (towards the left). Model 301e uses channel 2 & 4 PCB positions (jumpers W201 & W401).

Mic/Line: In addition to a factory installed input transformer, channel 5 (channel 2 on 301e) includes movable jumper straps which set gain and impedance. From the factory, this channel has a 600 ohm input impedance and proper gain for line level signals. To convert to standard Mic/Line operation, move jumper straps W505, W506, and W507 to the "MIC" position (towards the rear panel). Model 301e uses channel 4 PCB position (jumpers W405, W406, & W407). The input transformer does not need to be removed.

Input Transformers: In some applications, isolation from radio interference and ground potentials at the inputs may be necessary. Input transformers are available as an option, and circuit board mounting positions are provided for on each channel. Channel 5 already includes a factory installed input transformer (channel 2 on 301e). To install input transformers, solder them into positions T101-T601 on the circuit board, with Pin 1 of the transformer located at the square solder pad (T101 for channel 1, T201 for channel 2, etc.). When transformers are installed, two jumpers and two resistors per channel need to be removed. Remove jumpers W103-W603 and W104-W604 (W103 & W104 are for channel 1, W203 & W204 are for channel 2, etc.). Remove 1k ohm resistors R130-R630 and R131-R631 (R130 & R131 are for channel 1, R230 & R231 are for channel 2, etc.). Model 301e uses channel 2 & 6 PCB positions (T201, T601, W203, W204, W603, W604, R230, R231, R630, & R631). These components may either be de-soldered or clipped out.

Remote Controls: Wiring of remote controls is not an internal modification, and does not require that the mixer be opened, or even removed from a rack. When using a slide potentiometer as a remote control, wire with High (T) to the control voltage ("+10V"), Wiper (W) to the control terminal ("C"), and Low (B) to ground ("gnd"). When using a rotary potentiometer, wire with High (CW) to the control voltage ("+10V"), Wiper (W) to the control terminal ("C"), and Low (CCW) to ground ("gnd"). Potentiometers should be linear taper, of any value from 5k ohms to 50k ohms, and may be wired up to 2000 feet from the mixer. Cable should be 2-conductor with shield. If an on/off switch is utilized, "ON" position should connect the control voltage ("+10V") to the control terminal ("C"). Fixed or variable resistors may be used in conjunction with a switch to provide level & mute functions, or simply for adjustment of desired muting levels. Remove the factory installed jumper strap between "+10V" and "C" only when connecting remote controls.

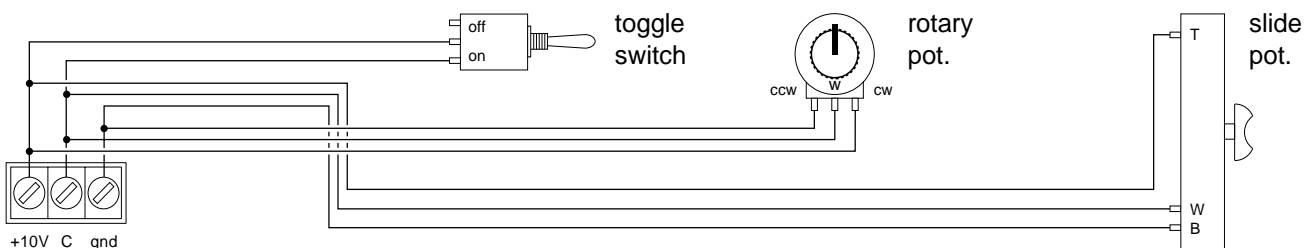

APPLICATIONS

Telephone Paging with Background Music Override

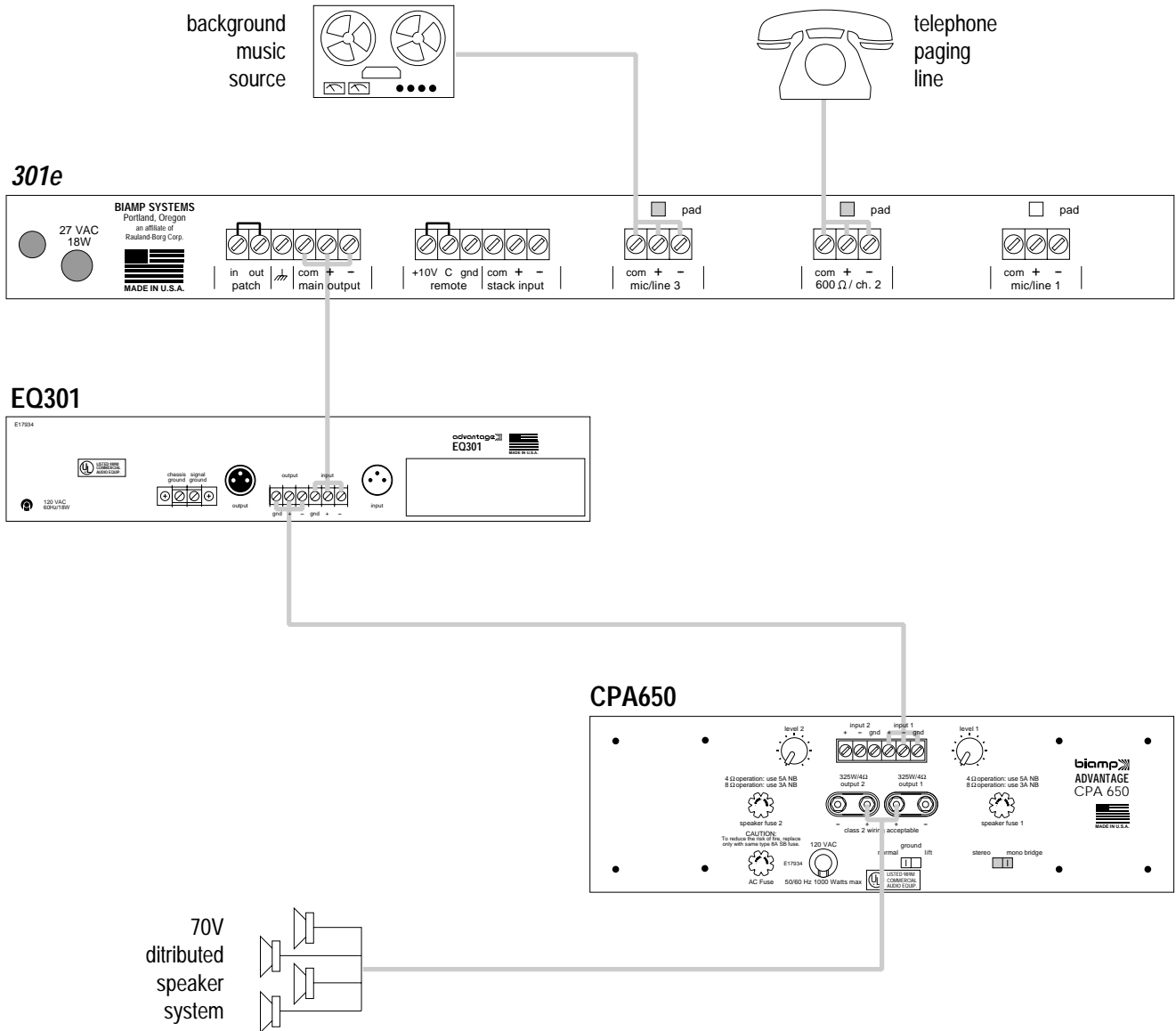

- A) Move the Channel 2 internal "Ducking" jumper to the "DUCK" position. This causes Channel 3 signal level to drop by 15dB whenever signal is present in Channel 2. (See Modifications/Accessories: "Ducking" on page 5.)
- B) Depress Channel 2 and Channel 3 rear panel Pad switches. This is appropriate for most standard line level input signals.
- C) Connect the background music source to the Channel 3 rear panel input terminals. (See Rear Panel: Inputs on page 3.)
- D) Connect the telephone paging line to the Channel 2 rear panel input terminals. (See Rear Panel: Inputs on page 3.)
- E) Adjust the front panel channel Trim & Level controls for appropriate levels. (See Front Panel: Trim and Level on page 2.)
- F) Adjust the front panel Bass, Treble, Limit Adjust, & Master Level controls as necessary. (See Front Panel on page 2.)
- G) Connect the 301e Main Output to the input of the equalizer (Advantage EQ301). (See Rear Panel: Main Output on page 3.)
- H) Connect the equalizer output to the input of the amplifier (Advantage CPA650). (The CPA650 amplifier is shown in mono-bridge mode with input to Ch. 1 and the output driving a 70V distributed system directly, without the need for an output transformer.)

APPLICATIONS

Microphone Paging with Background Music Override

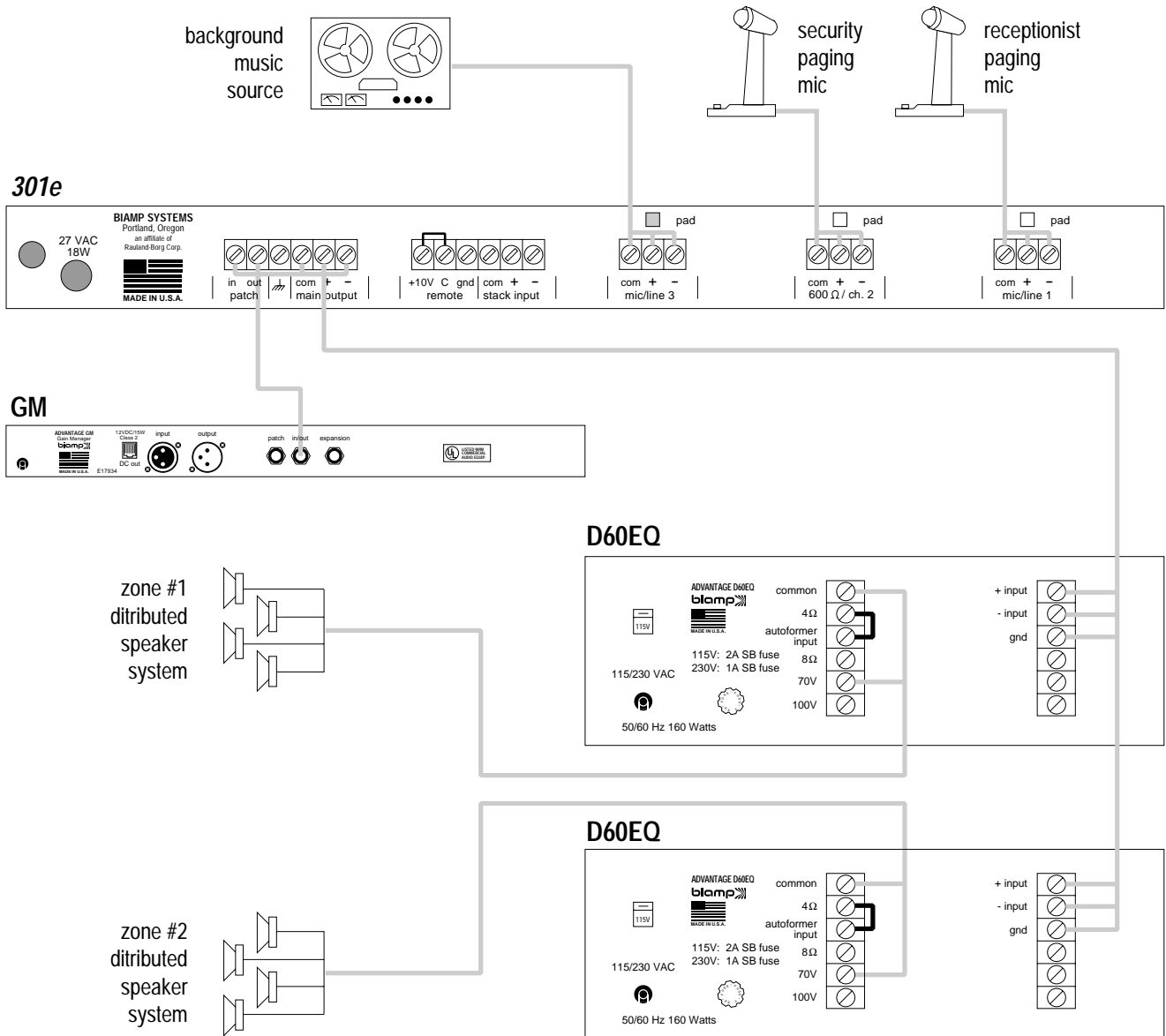

- Move the Channel 2 "Mic/Line" jumpers to the "MIC" position. This assigns Channel 2 to standard Mic/Line operation. (See Modifications/Accessories: Mic/Line on page 5.)
- Move the Channel 1 and Channel 2 internal "Ducking" jumpers to the "DUCK" position. This causes Channel 3 signal level to drop by 15dB whenever signal is present in Channel 1 or Channel 2. (See Modifications/Accessories: "Ducking" on page 5.)
- Depress the Channel 3 rear panel Pad switch. This is appropriate for most standard line level input signals.
- Connect the background music source to the Channel 3 rear panel input terminals. (See Rear Panel: Inputs on page 3.)
- Connect the paging mics to the Channel 1 and Channel 2 rear panel input terminals. (See Rear Panel: Inputs on page 3.)
- Adjust the front panel channel Trim & Level controls for appropriate levels. (See Front Panel: Trim and Level on page 2.)
- Adjust the front panel Bass, Treble, Limit Adjust, & Master Level controls as necessary. (See Front Panel on page 2.)
- Connect the 301e Patch terminals to the external processor (Advantage GM). (The GM maintains a consistent mixer output level.)
- Connect the 301e Main Output to the input of the equalizers/amplifiers (Advantage D60EQs). (The two D60EQs are both shown receiving signal from the 301e, but providing independent equalization and amplification for the two zones.)

APPLICATIONS

Multi-Purpose Room with Remote Control

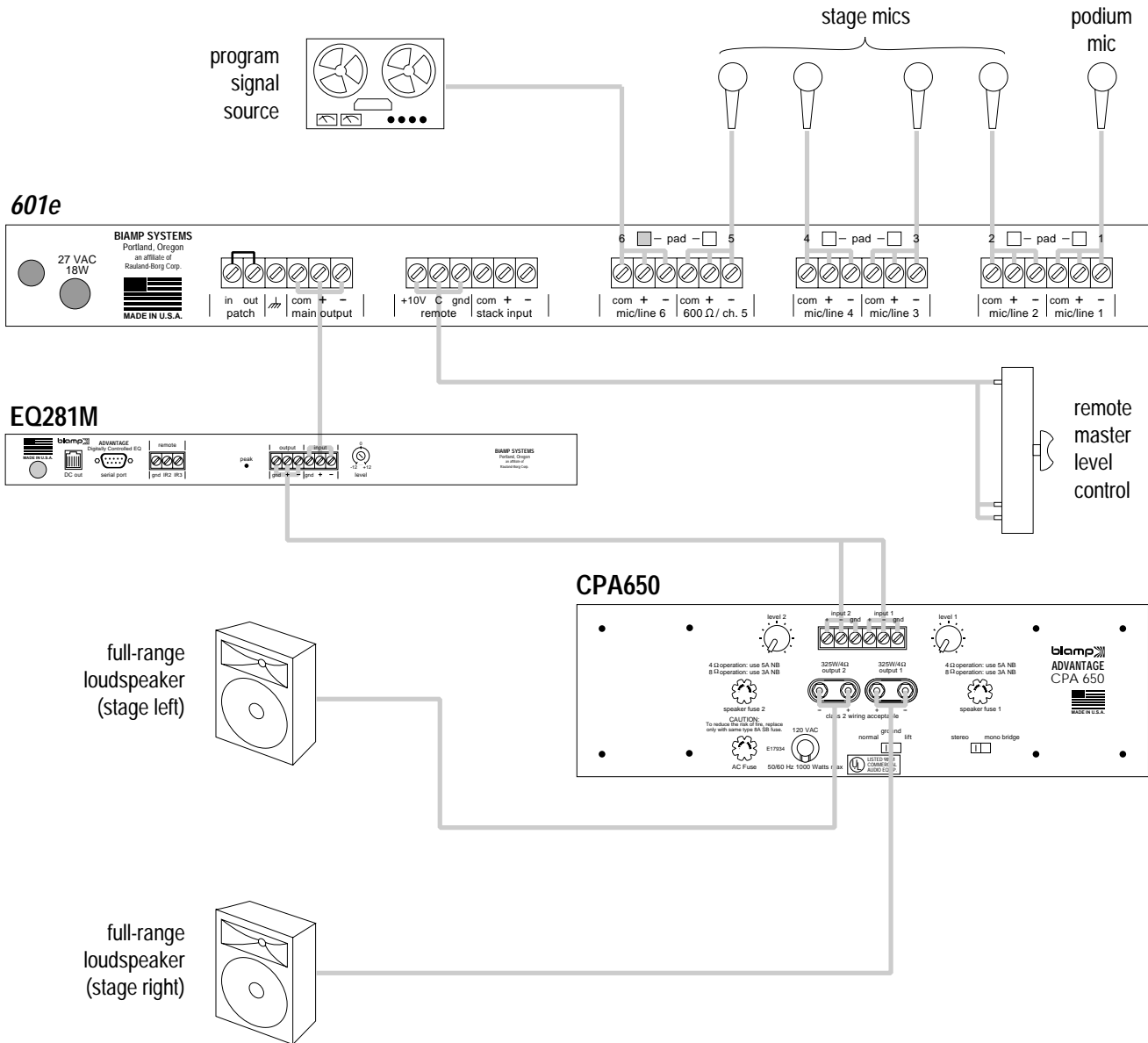

- A) Move the Channel 5 "Mic/Line" jumpers to the "MIC" position. This assigns Channel 5 to standard Mic/Line operation. (See Modifications/Accessories: Mic/Line on page 5.)
- B) Depress the Channel 6 rear panel Pad switch. This is appropriate for most standard line level input signals.
- C) Connect the background music source to the Channel 6 rear panel input terminals. (See Rear Panel: Inputs on page 3.)
- D) Connect the various mics to the Channels 1-4 rear panel input terminals. (See Rear Panel: Inputs on page 3.)
- E) Adjust the front panel channel Trim & Level controls for appropriate levels. (See Front Panel: Trim and Level on page 2.)
- F) Adjust the front panel Bass, Treble, Limit Adjust, & Master Level controls as necessary. (See Front Panel on page 2.)
- G) Connect the 601e Remote terminals to the remote master level control. (See Modifications/Accessories: Remote Control on page 5.)
- H) Connect the 601e Main Output to the input of the equalizer (Advantage EQ281M). (The EQ281M is programmable, and can provide four memory preset equalization curves, which are selectable for the various uses of the room.)
- I) Connect the EQ281M output to the inputs of the amplifier (Advantage CPA650). (The CPA650 is shown with input to both channels, providing independent amplification for the left & right stage speakers.)

APPLICATIONS

Small Church with Speech & Music

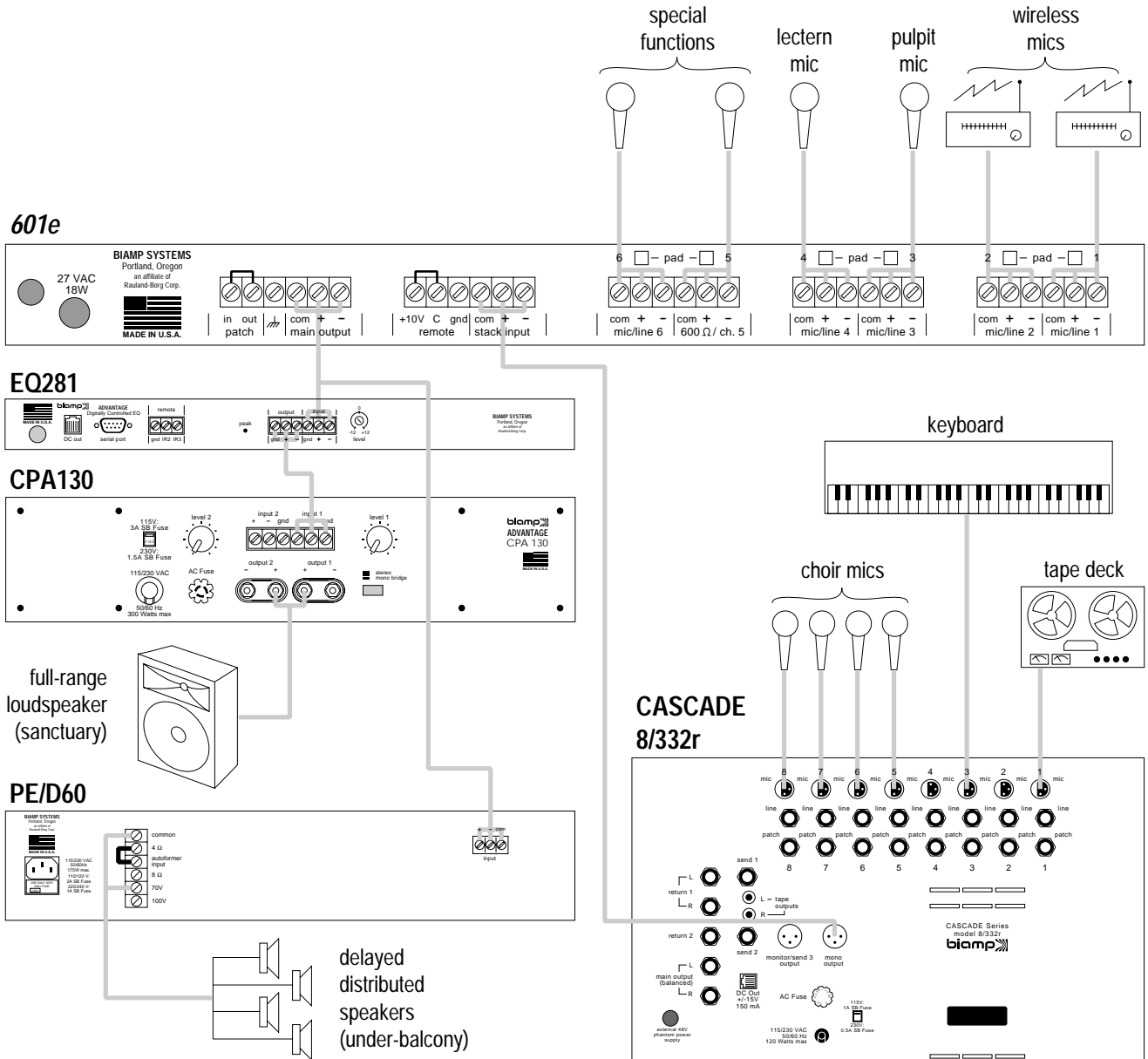

- A) Move the Channel 5 "Mic/Line" jumpers to the "MIC" position. This assigns Channel 5 to standard Mic/Line operation. (See Modifications/Accessories: Mic/Line on page 5.)
- B) Connect the various mics to the Channels 1~6 rear panel input terminals. (See Rear Panel: Inputs on page 3.)
- C) Connect the main output from the "music" mixer (Biamp Cascade 8/332r) to the 601e Stack Input terminals. (See Rear Panel: Stack Input on page 3.) (The Cascade 8/332r provides independent mixing for the choir mics, electronic keyboards, and tape playback.)
- D) Adjust the front panel channel Trim & Level controls for appropriate levels. (See Front Panel: Trim and Level on page 2.)
- E) Adjust the front panel Bass, Treble, Limit Adjust, & Master Level controls as necessary. (See Front Panel on page 2.)
- F) Connect the 601e Main Output to the input of the equalizers/amplifiers (Advantage EQ281 & Advantage PE/D60). (The PE/D60 provides delay, equalization, and amplification for the under-balcony speakers.)
- G) Connect the EQ281 output to the input of the amplifier (Advantage CPA130). (The CPA130 is shown in mono-bridge mode, providing amplification for the sanctuary speakers.)

BLOCK DIAGRAM

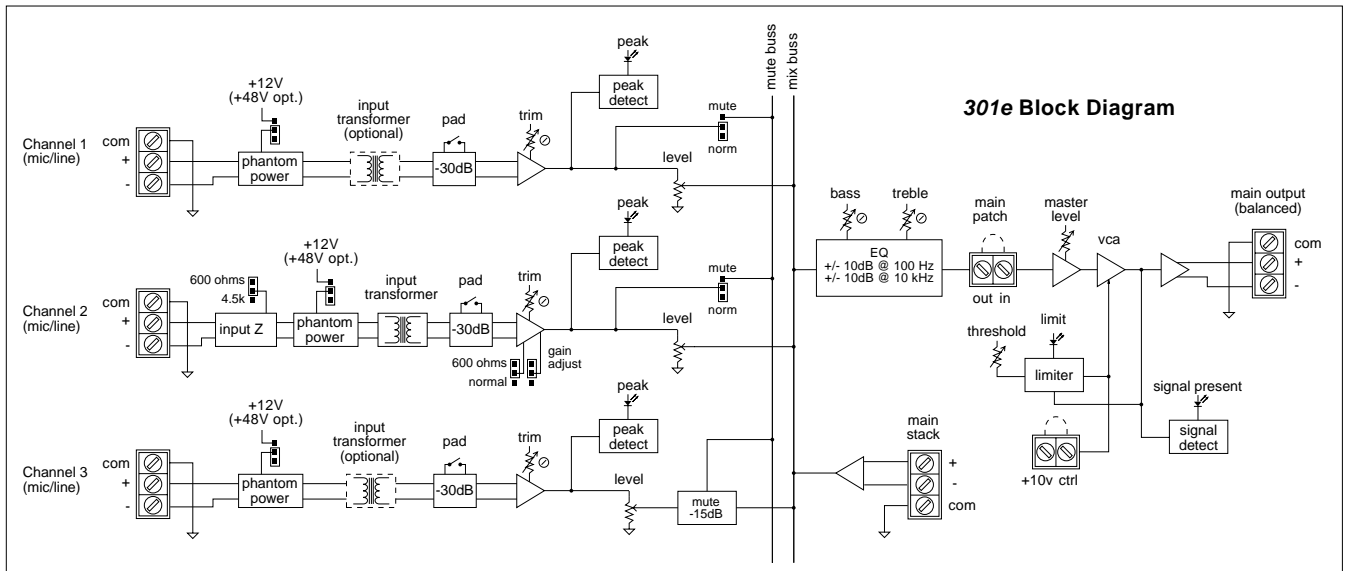
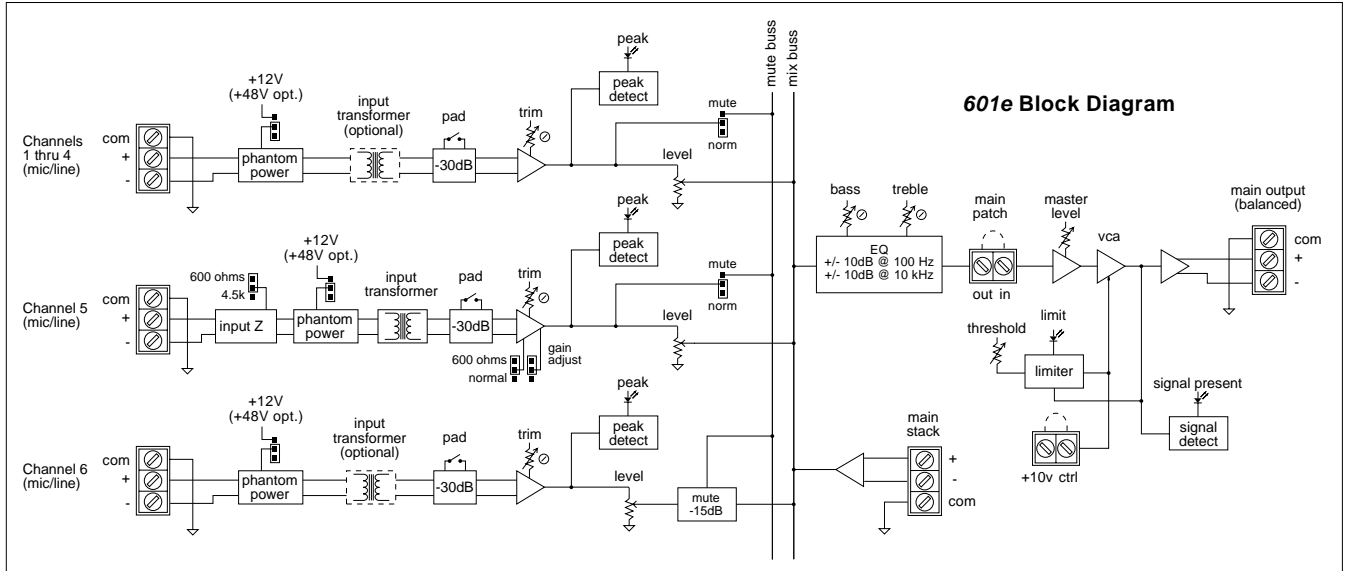

SPECIFICATIONS

Frequency Response (20Hz ~ 20kHz @ +4dBu):	+0/-1dB
Total Harmonic Distortion (20Hz ~ 20kHz @ +4dBu):	< 0.08%
Equivalent Input Noise (20Hz ~ 20kHz, 150 ohm term.):	-126dBu
Output Noise (20Hz ~ 20kHz):	
master level control down	< -85dBu
master level & one channel at nominal	< -75dBu
Maximum Gain:	
mic input to main output	81dB
main patch to main output	20dB
main stack to main output	22dB
Crosstalk (channel-to-channel, 20Hz~20kHz):	-55dB
Output Tone Controls:	
Treble	±10dB @ 10kHz
Bass	±10dB @ 100Hz
Output Limiter:	
attack time	1 mSec
release time	program dependent
threshold range	-35dB to limiter off
Remote Control Attenuation (0 VDC ~ +10 VDC):	-80dB ~ 0dB
Input Trim Control Range:	40dB
Input Pad Switch Attenuation:	30dB
Input Impedance:	
mic/line input (balanced)	4.55k ohms
transformer isolated line input (balanced)	600 ohms
main patch (unbalanced)	> 10k ohms
main stack (balanced)	20k ohms
Maximum Input:	
mic/line input & main patch	+30dBu
main stack	+15dBu
Output Impedance:	
main output (balanced)	100 ohms
main patch (unbalanced)	< 50 ohms
Maximum Output:	
main output (balanced)	+24dBu
main patch (unbalanced)	+18dBu
Power Requirements:	120/240VAC 50/60Hz
Power Consumption:	15 watts max.
Dimensions:	
height (1 rack space)	1.75 inches (44mm)
width	19 inches (483mm)
depth	7 inches (178mm)
Weight:	6 lbs. (2.72kg)

WARRANTY

BIAMP IS PLEASED TO EXTEND THE FOLLOWING 5-YEAR LIMITED WARRANTY TO THE ORIGINAL PURCHASER OF THE PROFESSIONAL SOUND EQUIPMENT DESCRIBED IN THIS OWNER'S MANUAL.

BIAMP Systems expressly warrants this product to be free from defects in material and workmanship for a period of 5 YEARS from the date of purchase as a new product from an authorized BIAMP dealer under the following conditions.

1. The Purchaser is responsible for completing and mailing to BIAMP, within 10 days of purchase, the attached warranty application.
2. In the event the warranted BIAMP product requires service during the warranty period, BIAMP will repair or replace, at its option, defective materials, provided you have identified yourself as the original purchaser of the product to any authorized BIAMP Service Center. Transportation and insurance charges to and from an authorized Service Center or the BIAMP factory for warranted products or components thereof to obtain repairs shall be the responsibility of the Purchaser.
3. This warranty will be VOIDED if the serial number has been removed or defaced; or if the product has been subjected to accidental damage, abuse, rental usage, alterations, or attempted repair by any person not authorized by BIAMP to make repairs; or if the product has been installed contrary to BIAMP's recommendations.
4. Electro-mechanical fans, electrolytic capacitors, and the normal wear and tear of appearance items such as paint, knobs, handles, and covers is not covered under this warranty.

5. BIAMP SHALL NOT IN ANY EVENT BE LIABLE FOR SPECIAL, INCIDENTAL, OR CONSEQUENTIAL DAMAGES, INCLUDING LOST PROFITS, LOSS OF USE, PROPERTY DAMAGE, INJURY TO GOODWILL, OR OTHER ECONOMIC LOSS OF ANY SORT. EXCEPT AS EXPRESSLY PROVIDED HEREIN, BIAMP DISCLAIMS ALL OTHER LIABILITY TO PURCHASER OR ANY OTHER PERSONS ARISING OUT OF USE OR PERFORMANCE OF THE PRODUCT, INCLUDING LIABILITY FOR NEGLIGENCE OR STRICT LIABILITY IN TORT.

6. THIS WARRANTY IS IN LIEU OF ALL OTHER WARRANTIES EXPRESSED OR IMPLIED. BIAMP EXPRESSLY DISCLAIMS ALL IMPLIED WARRANTIES OF MERCHANTABILITY AND FITNESS FOR A PARTICULAR PURPOSE. THE REMEDIES SET FORTH HEREIN SHALL BE THE PURCHASER'S SOLE AND EXCLUSIVE REMEDIES WITH RESPECT TO ANY DEFECTIVE PRODUCT. THE AGENTS, EMPLOYEES, DISTRIBUTORS, AND DEALERS OF BIAMP ARE NOT AUTHORIZED TO MODIFY THIS WARRANTY OR TO MAKE ADDITIONAL WARRANTIES BINDING ON BIAMP. ACCORDINGLY, ADDITIONAL STATEMENTS SUCH AS DEALER ADVERTISEMENTS OR REPRESENTATIONS DO NOT CONSTITUTE WARRANTIES BY BIAMP.

7. No action for breach of this warranty may be commenced more than one year after the expiration of this warranty.

Thank you for purchasing BIAMP...
AMERICAN SOUND CRAFTSMANSHIP

Biamp Systems
10074 S.W. Arctic Drive
Beaverton, Oregon 97005
(503) 641-7287
<http://www.biamp.com>