

3-MOTOR 4-HEAD TAPE DECK

RT-707

SERVICE MANUAL



MODEL RT-707 COMES IN TWO VERSIONS DISTINGUISHED AS FOLLOWS:

Type	Voltage	Remarks
KU	120V only	U.S.A. model
KC	120V only	Canada model

CONTENTS

1.	SPECIFICATIONS	3
2.	CONNECTION DIAGRAM	4
3.	FRONT PANEL FACILITIES	5
4.	BLOCK DIAGRAM	7
5.	LEVEL DIAGRAM	9
6.	CIRCUIT DESCRIPTIONS	
6.1	Power Supply	10
6.2	Control Circuit	10
6.3	Direction Switch Circuit	13
6.4	Switching Circuit, Muting Circuit	14
6.5	Playback Amplifier	15
6.6	Bias Oscillator	16
6.7	Recording Amplifier	16
6.8	Frequency Generator	17
7.	DISASSEMBLY	
7.1	Bonnet	21
7.2	Rear Panel	21
7.3	Bottom Plate	22
7.4	Front Panel	22
8.	PARTS LOCATIONS	
8.1	Front Panel View	23
8.2	Front View With Front Panel Removed	25
8.3	Top View With Bonnet Removed	27
8.4	Bottom View With Bottom Panel Removed	29
8.5	Rear Panel View	31
9.	MECHANICAL ADJUSTMENTS	
9.1	Reel Base Height Adjustment	33
9.2	Brake Adjustment	33

9.3	Takeup Torque, Back Tension Adjustment	34
9.4	Pinch Roller Pressure Adjustment	35
9.5	Pause Adjustment	36
9.6	Tape Speed Adjustment	36
10.	HEAD ADJUSTMENTS	
10.1	Head Rough Adjustment	37
10.2	Playback Head Adjustment	38
10.3	Record Head Adjustment	38
11.	ELECTRICAL ADJUSTMENTS	
11.1	Playback Level Adjustment	39
11.2	Playback Equalizer Adjustment	39
11.3	Level Meter 0VU Adjustment	39
11.4	Dummy Coil Adjustment	40
11.5	Bias Trap Adjustment	40
11.6	Recording Bias Adjustment	40
11.7	Record/Play Frequency Response	41
11.8	Recording Level Adjustment	41
12.	EXPLODED VIEW	42
13.	SCHEMATIC DIAGRAMS, P.C. BOARD PATTERNS AND PARTS LIST	
13.1	Miscellaneous Parts List	59
13.2	External Appearance of Transistors, ICs and Circuit Diagrams of IC	60
13.3	Connection Diagram	61
13.4	Schematic Diagram	63
13.5	Playback Amplifier Assembly (RWF-069)	65
13.6	Meter Amplifier Assembly (RWX-155)	71
13.7	Power and Oscillation Assembly (RWR-053)	73
13.8	Indicator Assembly (RWX-142)	78
13.9	Fuse Assembly (RWX-141)	79
13.10	Equalizer Amplifier Assembly (RWX-154)	80
13.11	Head Amplifier Assembly (RWF-070)	82
13.12	Connector Assembly L (RWX-151)	84
13.13	Connector Assembly R (RWX-152)	85
13.14	Function Switch Assembly (RWS-052)	86
13.15	MIC Amplifier Assembly (RWF-065)	89
13.16	Control Assembly (RWG-070)	92
13.17	Servo Amplifier Assembly (RWG-076)	95
13.18	Switch Assembly (RWS-058 KC type)	102
	(RWS-059 KU type)	
14.	PACKING	106

1. SPECIFICATIONS

Type	4-track, 2-channel stereo tape deck (Recording, playback with reverse playback)
Operation system	Solenoid drive, Pushbutton direct change system, Timer can be set for recording and playback.
Heads	Recording Head ; 1 Erase Heads ; 1 Forward playback Head ; 1 Reverse playback Head ; 1
Motors	Capstan drive motor ; 1 (FG-system, AC servo, direct drive) Reel base drive motors ; 2 (6-pole inner rotor induction type)
Acceptable Reel Size	7in (17cm)
Tape Speed	19cm/s (7-1/2ips), 9.5cm/s (3-3/4ips) ±0.5%
Fast Forward/Rewind Times	Less than 100 sec. with 7-inch reel and 370m tape
Wow and Flutter	Less than 0.05% WRMS (19cm/s) Less than 0.08% WRMS (9.5cm/s)
Signal-to-Noise Ratio	More than 58dB
Total Harmonic Distortion	Less than 1% (19cm/s)
Frequency Response	
19cm/s	20Hz to 28,000Hz (30Hz to 24,000Hz ±3dB)
9.5cm/s	20Hz to 20,000Hz (30Hz to 16,000Hz ±3dB)
Crosstalk	More than 50dB
Channel Separation	More than 50dB
Erasure Rate	More than 70dB
Recording Bias Frequency	125kHz
Equalization	NAB Standards
Inputs (Sensitivity/Maximum allowable level/Input impedance)	
MIC; 0.25mV/125mV/27kΩ, 6mm diam. jacks (suitable microphone, 250Ω to 30kΩ)	
LINE; 50mV/25V/100kΩ, DIN; 16mV/8V/1.3kΩ, DIN standards	
Outputs (Reference level/Maximum level/Load impedance)	
LINE; 450mV/700mV/50kΩ, DIN; 450mV/700mV/50kΩ, DIN standards	
HEADPHONES; 70mV/8Ω, 6mm diam. jack	
Semiconductors	67 transistors (4 FET's), 5 IC's, 47 diodes (1 thyristor, 2 LED's, 4 Zener diodes, 2 varistors,)
Accessory Functions	
• Pitch control (more than +6% of rated tape speed)	
• Auto reverse playback (with sensing tape: manual reverse is possible)	
• Auto repeat (counter-interlocked)	
• Recording mode switches (L, R independent)	
• Tape selectors: BIAS (STD/LH); EQ (STD/LH)	
• MIC/LINE mixing	
• Output volume controls	
• Pause indicator lamp	
Power Requirements	AC 120V 60Hz
Power Consumption	120 watts, Max.
AC Outlets	Unswitched (300W max.) x 1
Dimensions	480(W) x 230(H) x 356(D)mm 18-29/32 x 9-1/16 x 14in
Weight	Without package; 20.0kg 44lb 1oz With package; 23.5kg 51lb 13oz

Accessories	<ul style="list-style-type: none"> • 7in metal reel (Pioneer PR-85) x 1 • Connecting cord with pin plugs x 2 • Head cleaning kit x 1 • Sensing tape x 1 • Splicing tape x 1 • Operating instructions x 1
-----------------------	--

NOTE:

*Specifications and the design subject to possible modification
without notice due to improvements.*

2. CONNECTION DIAGRAM

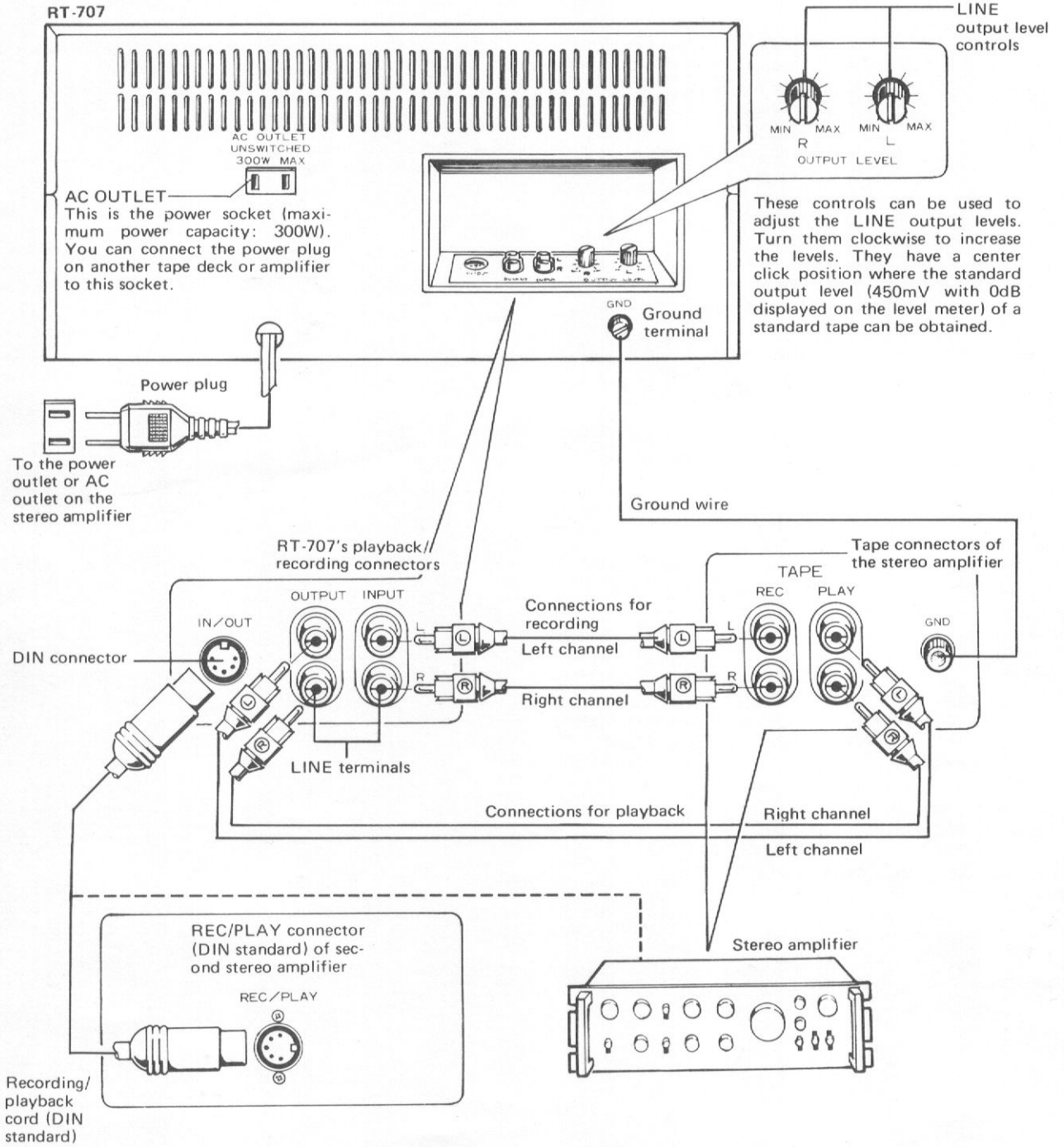

3. FRONT PANEL FACILITIES

POWER SWITCH
Push this switch and power is supplied to the tape deck. Push for a second time to turn the power off.

SPEED SWITCH
This switch selects the tape speed. Push for a 9.5cm/s speed; push again for a 19cm/s speed (released position).
19cm/s: Used for recording music programs, etc.
9.5cm/s: Used for recording lengthy conversations, etc.

PAUSE LAMP
This green lamp lights up when the PAUSE button is pressed to indicate the tape has stopped temporarily.

PHONES JACK
This is the output jack for stereo headphones. Signals selected by the MONITOR switch are available here. Use it when you want to monitor the recording or listen to a performance directly taped from the RT-707. The output level is not variable.

MIC JACKS
These are the input jacks for microphone recording. The L (left) and R (right) channels can be used independently. Only the microphones' input signals are recorded if the REC/PLAY connector (DIN specifications) on the rear panel and the MIC jacks are connected at the same time. As long as the microphones have a standard 6mm diameter plug, you can use either a low impedance (600-ohms) or high impedance (10 – 50kohms) type.

MIC RECORDING LEVEL CONTROLS
Use these controls to adjust the recording level when you are recording with a microphone (or microphones) or when you are using the rear panel REC/PLAY connector (DIN standard). Use the outer control for the right and the inner control for the left channel. Input signals from both the MIC jacks and the REC/PLAY connector cannot be recorded simultaneously.

LINE RECORDING LEVEL CONTROLS
Adjust the recording input level from the LINE INPUT terminals on the rear panel. The level increases as the controls are turned to the right. The outer control is for the right channel and the inner, for the left.

RECORDING LAMP (REC)
This red lamp lights up during recording. Check that it has lit up before recording.

MONITOR SWITCH
Use this switch to monitor your recording.
TAPE: Allows you to listen to the recorded signals.
SOURCE: You can listen to the signals before recording if this position is selected (press switch once).
If this switch is switched alternately to SOURCE and TAPE during recording, you can compare the sound signals before and after recording.

TAPE COUNTER
This indicates how much tape has been recorded or played back and how much there is left over.

REPEAT BUTTON
This button allows you to reverse the tape forward for reverse playback automatically. If you remember to work the tape counter and REPEAT button, then the tape will automatically be reversed and the tape deck will be set to forward playback when the "0000" display on the tape counter gives way to "9999" during reverse playback. Be sure to release this button when you do not require repeated playback.

COUNTER RESET BUTTON
Push this button to reset the tape counter to "0000"

BIAS SWITCH
This selects the recording bias current according to the type of tape used for recording. Push for LH tapes; push again for STD tapes (released position).
STD: For standard tapes.
LH: For low noise and high output tapes.

EQ SWITCH
This selects the recording equalization characteristics according to the type of tape used. Select same position for playback as for recording according to the characteristics of the recording tape. Push for LH; push again for STD (released).
STD: For standard tapes.
LH: For low noise and high output tapes.

REC MODE SWITCHES (L. R)
Depress these switches when recording.
L: Use this switch for L (left) channel recording.
R: Use this switch for R (right) channel recording.
For stereo recording, make sure that you depress both switches.

TAPE DIRECTION SELECTOR BUTTONS
These buttons allow you to select the direction of tape play during playback. When depressed, the button's lamp will light up to indicate the direction of tape play.
Forward playback: The tape runs from left to right.
Reverse playback: The tape runs from right to left.
When you are recording, you cannot change the direction of tape play even by depressing this button. The tape will always run in a forward direction.

PAUSE BUTTON
This temporarily stops the tape during tape play. When pressed during recording or playback, the tape merely stops. When pressed again, the tape starts to run. This button does not work during fast forward or rewind.

FUNCTION BUTTONS
◀◀ **REWIND:** This cause the tape to be wound at a high speed from the right to the left reel.
▶▶ **FAST FORWARD:** This causes the tape to be wound at a high speed from the left to the right reel.
PLAY: For tape playback, or recording, push this button.
REC: To record, press this button together with the PLAY button.
■ **STOP:** This stops the tape and releases the other function buttons.

NOTE:
• The function buttons will not return to their preset positions if the power is turned off.
• The tape will always run in a forward direction when the POWER switch is depressed to the ON position.
• If you depress both the PLAY and REC buttons with the tape set to the reverse playback direction, then the tape will sometimes move slightly backwards and then start to run forwards. Therefore, when recording, make sure that you set the DIRECTION button to the forward playback position.
• There is no need to press the (■) stop button if you want to change over from one function to another.

LEVEL METERS
These allow you to read out the levels during recording and playback. When the MONITOR switch is set to SOURCE, they indicate the input signal level, and when set to TAPE, they indicate the playback output level.

CAPSTAN
This rotates when the power is switched on. Together with the pinch roller, it keeps the tape at its rated speed.

PITCH CONTROL KNOB
You can use this to make the tape travel 6% faster or slower than the normal tape speed during playback. When set to the central position, the tape speed is 19cm/s or 9.5cm/s (standard values). Turn the control to the left and the speed drops and the musical steps are lowered; conversely, turn it to the right, and the speed rises and the musical steps are raised. This control cannot be used during recording.

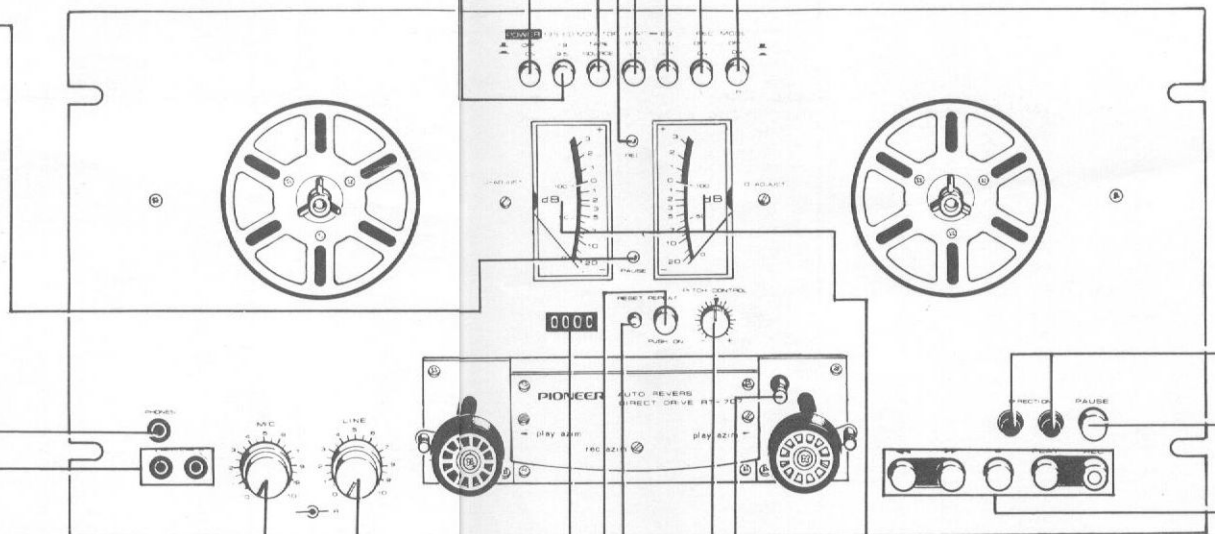

4. BLOCK DIAGRAM

NOTE:
The number which are circled in the block diagram indicated the points which are to be measured in the level diagram.

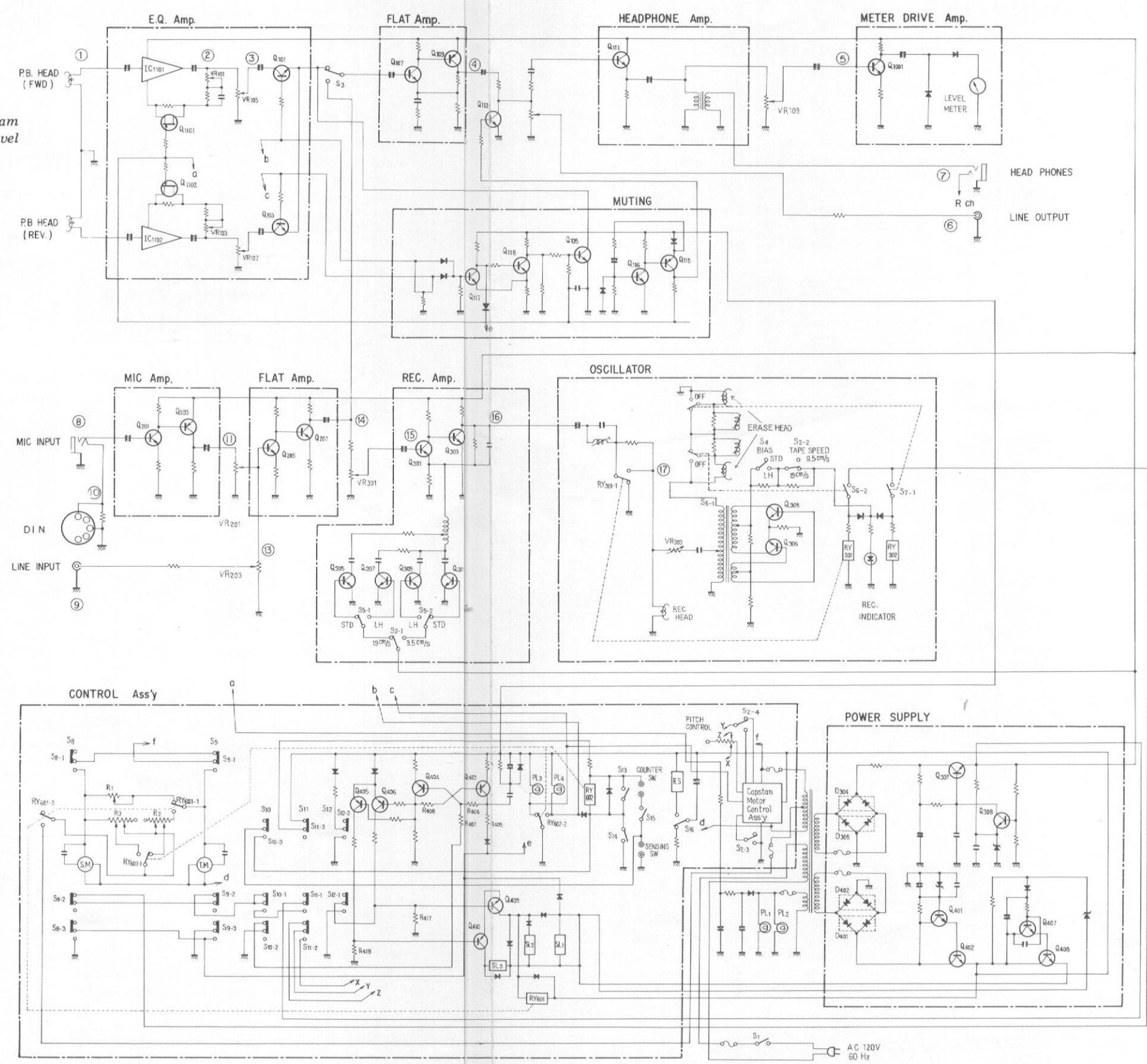

- SWITCHES**
- S1 : POWER
 - S2 : SPEED
 - S3 : MONITOR
 - S4 : BIAS
 - S5 : E Q
 - S6 : RECORD LEFT
 - S7 : RECORD RIGHT
 - S8 : REW
 - S9 : FWD
 - S10 : PLAY
 - S11 : REC
 - S12 : PAUSE
 - S13 : FWD
 - S14 : REVERSE
 - S15 : REPEAT
 - S16 : SHUT OFF
- RELAYS**
- RY301 : REC LEFT
 - RY302 : REC RIGHT
 - RY601 : PLAY
 - RY602 : DIRECTION
- LAMPS**
- PL1 : LEVEL METER LEFT
 - PL2 : LEVEL METER RIGHT
 - PL3 : FWD INDICATOR
 - PL4 : REVERSE INDICATOR

5. LEVEL DIAGRAM

NOTES:
 0dBv=1V
 Frequency: 1kHz
 The level measurement points are indicated on the block diagram.

[PLAYBACK]

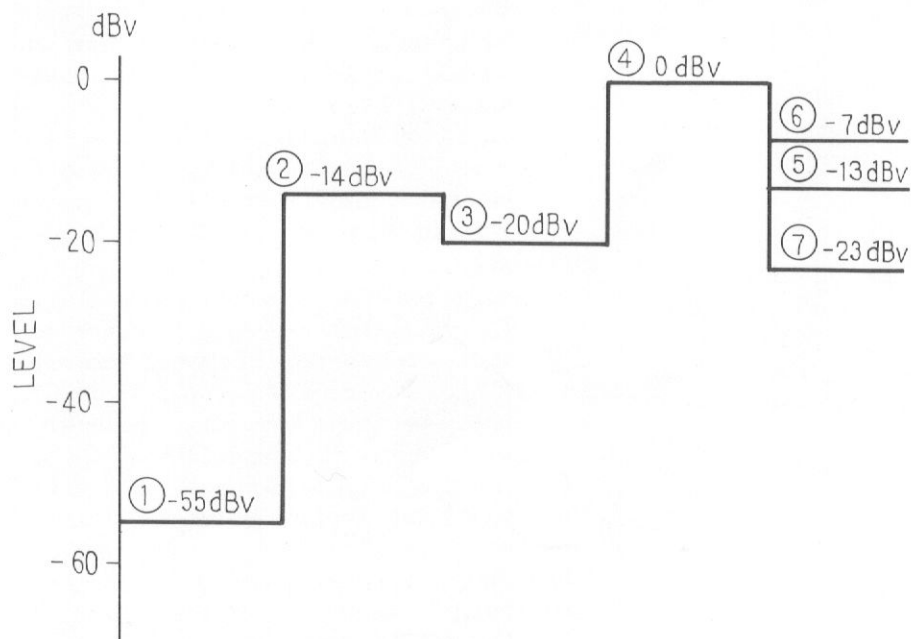

[RECORDING]

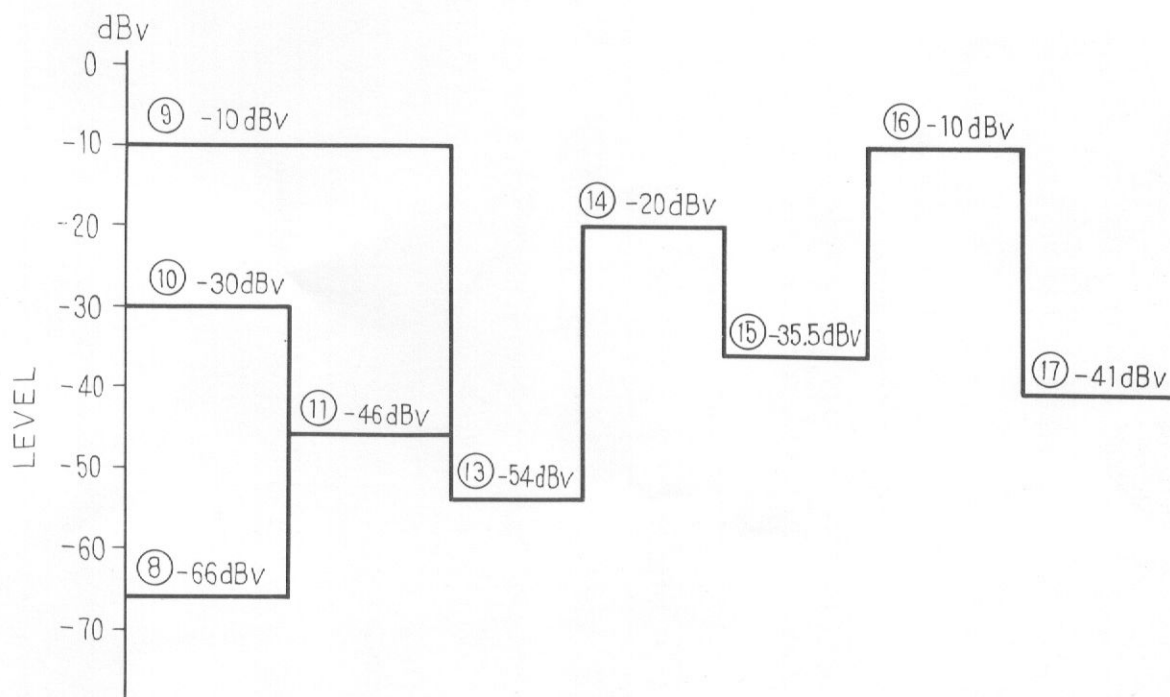

6. CIRCUIT DESCRIPTIONS

The block diagram is shown on page 7.

Model RT-707 is an open reel tape deck characterized by direct drive 4-track 2-channel configuration, 3 motors, 4 heads autoreverse

The sensor touch pushbuttons used in most 3-motor tape decks necessitate a relatively large number of relays in the transport control electronics; the RT-707, however, uses locking type pushbuttons which permit simplified circuit construction and also facilitate automatic unattended recording in conjunction with a timer.

6.1 POWER SUPPLY

When the power switch S_1 is switched on, AC100V is supplied to the capstan motor from the secondary side of the power transformer, and the motor begins to rotate. A DC voltage rectified in D_{401} , D_{402} , stabilized in the stabilizer formed by Q_{401} , Q_{402} and ZD_{401} , is supplied to the control circuit (Fig. 1).

6.2 CONTROL CIRCUIT

The control circuit is shown in Fig. 2. Table 1 indicates the transistor states for the different transport modes.

● Play Function (Fig. 2)

1. When the play button S_{10-2} is pushed, ground connection of R_{407} is interrupted and the base circuit of Q_{404} is opened. No current can flow through Q_{404} , and it enters OFF state.
2. +B voltage causes current to flow along the route $D_{405} \rightarrow Q_{406} \rightarrow R_{413} \rightarrow R_{410}$, whereby Q_{406} is turned ON.
3. As R_{417} is connected between base and emitter of Q_{409} , this transistor is turned ON. The collector current of Q_{409} activates brake solenoid SL_1 , pinch solenoid SL_2 and play relay RY_{601} .
4. +B current also flows along path $D_{405} \rightarrow Q_{405} \rightarrow R_{411} \rightarrow R_{410}$, whereby Q_{405} becomes ON.
5. As R_{418} is connected between base and emitter of Q_{410} , base current can flow and the transistor becomes ON. Q_{410} collector current activates PAUSE solenoid SL_3 .

Operation of brake solenoid SL_1 releases the brakes of the supply motor (SM) and take-up motor (TM). Operation of the pinch solenoid SL_2 causes the pinch roller to be pressed against the capstan. Operation of the play relay RY_{601} enables AC 70V from the secondary side of the power transformer (see Fig. 1) to be applied to the supply and take-up motors through slide resistors R_2 and R_3 .

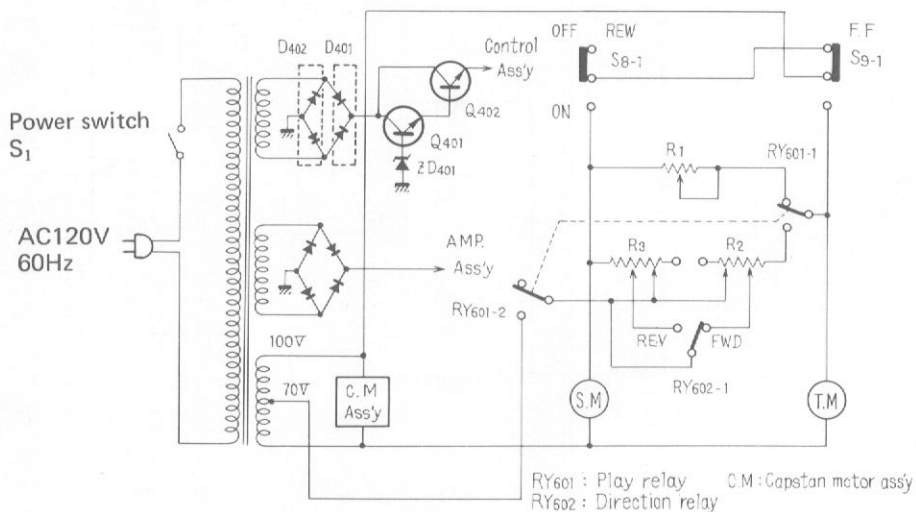

Fig. 1

● Rewind (& Fast Forward) Function (Fig. 2)

1. When the rewind button S_{8-3} is pushed, +B current flows along the path brake solenoid $SL_1 \rightarrow D_{407} \rightarrow S_{8-3}$, and SL_1 operates, releasing the supply and take-up reel brakes.
2. As shown in Fig. 1, AC100V is applied to the supply motor via F.F. button S_{9-1} and Rewind button S_{8-1} , and tape rewind begins.
3. AC100V also flows to the take-up motor via F.F. button $S_{9-1} \rightarrow$ rewind button $S_{8-1} \rightarrow$ slide resistor $R_1 \rightarrow$ play relay RY_{601} . The slide resistor serves to apply the proper amount of back tension to the take-up motor in rewind mode.
4. In F.F. mode, on the other hand, AC100V from the secondary side of the power transformer is applied to the take-up motor through F.F. button S_{9-1} .
5. AC100V also flows to the supply motor via the route formed by $S_{9-1} \rightarrow$ play relay $RY_{601} \rightarrow$ slide resistor R_1 . The slide resistor serves to apply the proper amount of back tension to the supply motor in fast forward mode.

● Solenoid Voltage Control Circuit (Fig. 2)

When transport functions are switched, operating current of the solenoids must be temporarily increased to effect the switching action, but current must be reduced again immediately to avoid overheating of the solenoids.

1. When, for example, the play button is pushed, a surge of charge current (base current from Q_{407}) flows to C_{408} , and Q_{407} is turned ON.
2. Brake solenoid SL_1 , pinch solenoid SL_2 , play relay RY_{601} and pause solenoid SL_3 are connected as loads to Q_{408} . As explained under PLAY FUNCTION, above, these solenoids operate in play mode, whereby the Q_{407} emitter current becomes the Q_{408} base current, turning Q_{408} ON.
3. As soon as C_{408} has been charged, bias of Q_{407} returns to the normal operating value determined by stabilization in R_{415} , ZD_{402} .

Table 1

Transport Mode	Transistors in ON state	Transistors in OFF state
STOP	Q_{404}	$Q_{403}, Q_{405}, Q_{406}, Q_{409}, Q_{410}$
PLAY	$Q_{403}, Q_{405}, Q_{406}, Q_{409}, Q_{410}$	Q_{404}
FF/REW	Q_{404}	$Q_{403}, Q_{405}, Q_{406}, Q_{409}, Q_{410}$
PAUSE	$Q_{403}, Q_{405}, Q_{406}, Q_{410}$	Q_{404}, Q_{409}

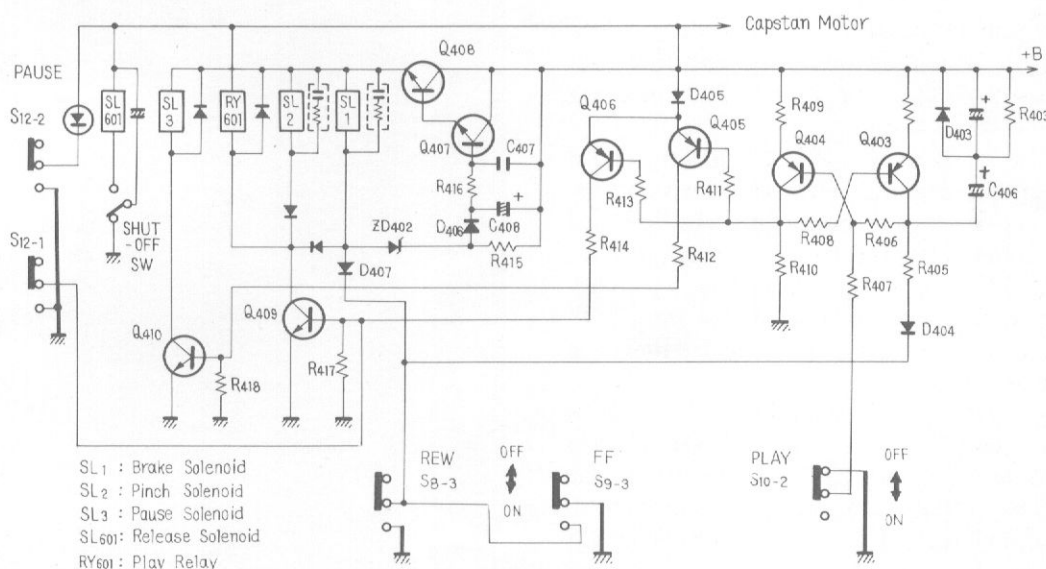

Fig. 2

● Time Lag In Switching Functions (Fig. 2)

When the transport is switched from rewind (or fast forward) directly to play mode, it is necessary in the interest of tape protection to bring the tape to a standstill for a certain length of time.

Switchover from fast forward or rewind to play

1. In F.F. (or rewind) mode, Q_{404} base current flows via the route formed by $R_{409} \rightarrow Q_{404} \rightarrow R_{407} \rightarrow$ play button S_{10-2} , and Q_{404} is in ON state.
2. Therefore (and because the Q_{403} base is connected to the Q_{404} collector via R_{408}), reverse bias is applied and Q_{403} is OFF.
3. +B voltage causes a current flow through $R_{403} \rightarrow C_{406} \rightarrow R_{405} \rightarrow D_{404}$, whereby C_{406} (timing capacitor) is charged.
4. When the Play button is pushed, the F.F. switch S_{9-3} is turned off, and C_{406} begins to discharge via $D_{403} \rightarrow R_{409} \rightarrow Q_{404} \rightarrow R_{406}$. As Q_{404} base current gradually decreases, its internal resistance goes up and Q_{404} attains OFF state.
5. When Q_{404} becomes OFF, Q_{405} , Q_{406} , Q_{409} and Q_{410} become ON (as explained under PLAY FUNCTION, above).
6. Therefore, the brake solenoid SL_1 , pinch solenoid SL_2 , play relay RY_{601} and Q_{410} , operate and the unit enters play mode.
7. The required stop time between pushing of the play button and start of play is determined by the discharge time of C_{406} ; it is approximately 2 seconds.

● Pause Function (Fig. 2)

1. When the pause button S_{12} is pushed while the transport is in play or rec mode, potential at the base of Q_{409} becomes 0V, meaning that Q_{409} becomes OFF.
2. Thereby the loads on Q_{409} , i.e. brake solenoid SL_1 and pinch solenoid SL_2 are released; supply and take-up motor brakes are applied and the pinch roller retracted from the capstan.
3. Play relay RY_{601} also opens, and AC70V current flow to the take-up and supply motors is interrupted. The motors stop, the transport is new in pause mode.
4. The pause indicator LED also lights.
5. When pause switch S_{12} is released, current again flows through the base of Q_{409} , the transistor becomes ON, brake solenoid SL_1 , pinch solenoid SL_2 , play relay RY_{601} and pause solenoid

SL_3 operate, and play or rec mode is resumed. Refer to PLAY FUNCTION, below.

NOTE:

With the pause switch S_{12} on, Q_{410} remains on, and +B voltage is still applied to pause solenoid SL_3 . The pinch roller is therefore retracted only about 2mm from the capstan.

● Record Function (Fig. 3)

1. The unit is put into recording mode when the play (S_{10-2}) and rec (S_{11-3}) buttons are operated at the same time.
2. +B current flow is as follows; rec button $S_{11-1} \rightarrow$ play button $S_{10-1} \rightarrow$ F.F. button $S_{9-2} \rightarrow$ REW button $S_{8-2} \rightarrow$ recording switch S_6 (S_7) \rightarrow D_{702} (D_{703}) \rightarrow speed switch $S_{2-2} \rightarrow$ bias switch $S_4 \rightarrow$ OSC assembly. Current is also supplied to the rec indicator LED, D_{801} .
3. Output from the bias oscillator is supplied to the recording and erase heads.
4. At the same time, recording signal current (which is grounded through rec relays RY_{301} and RY_{302} in other modes) is supplied to the recording head to be recorded on tape. Relay correspondences: R_{301} left channel, R_{302} right channel.

NOTES:

- Functions of the control circuit in rec mode are the same as in play mode.
- The above explanations of rec functions refer to stereo recordings.

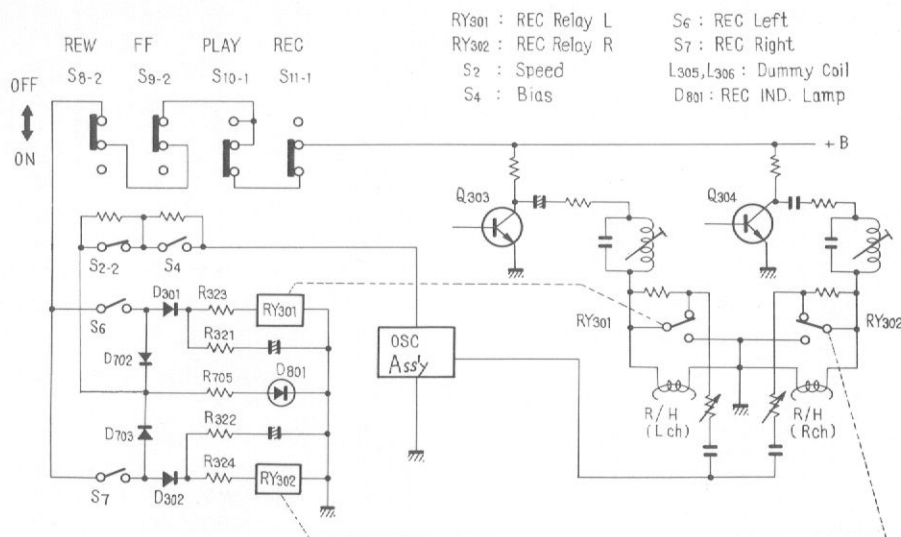

Fig. 3

6.3 DIRECTION SWITCH CIRCUIT

Fig. 4 shows the direction switch circuit diagram.

● Forward Play

1. When the power switch S_1 is turned on, current caused by +B flows along the route formed by reversing relay RY_{901} (and forward indicator lamp PL_3) → direction change relay RY_{601-2} → ground.
2. Relay RY_{901} thus operates, causing the capstan motor to rotate in forward direction, and lighting the forward indicator lamp in the FWD direction button.
3. If now the play button is pushed, forward play will begin.

● Reverse Play

1. When the direction change switch S_{14} is depressed, +B will flow along the following path: rec button S_{11-3} → R_{601} → direction change relay RY_{602} → direction change switch S_{14} → ground.
2. The direction change relay RY_{602} operates, changing its contact points for reverse direction.
3. This interrupts the current through the reversing relay RY_{901} (and FWD indicator lamp). Due to the contact points in relay RY_{901} , polarity in the main motor coil is reversed, and the capstan motor begins to rotate in the reverse direction. The REV indicator lamp lights.

● Auto Reverse Function

1. Automatic reversing of the tape travel direction can be effected by attaching a length of conductive sensing tape near the tape end.
2. As the sensing switch is short-circuited by the sensing tape, a current path is formed for +B: rec button S_{11-3} → R_{601} → direction change relay RY_{602} → play button S_{10-2} → sensing switch → ground. Thereby, tape travel direction is reversed, because the direction change relay RY_{602} operates.

● Repeat Function

1. When the repeat button S_{15} is engaged and the tape counter reset to 0000, the unit is ready for automatic repeat function. First play the tape in normal forward direction.
2. Sensing tape will cause automatic reverse in travel direction (as explained above).
3. As the tape reverses past the 0000 position of the counter and the counter returns to 9999, the tape counter switch is activated.
4. Action of the tape counter switch short-circuits the direction change relay RY_{602} , the relay's contact points are opened, and forward play resumes.

The unit will thus repeat playing the section between 0000 and sensing tape indefinitely.

NOTE:

Automatic resumption of forward play at counter reading 9999 will also take place if the unit has been switched to reverse play manually, i.e. without sensing tape.

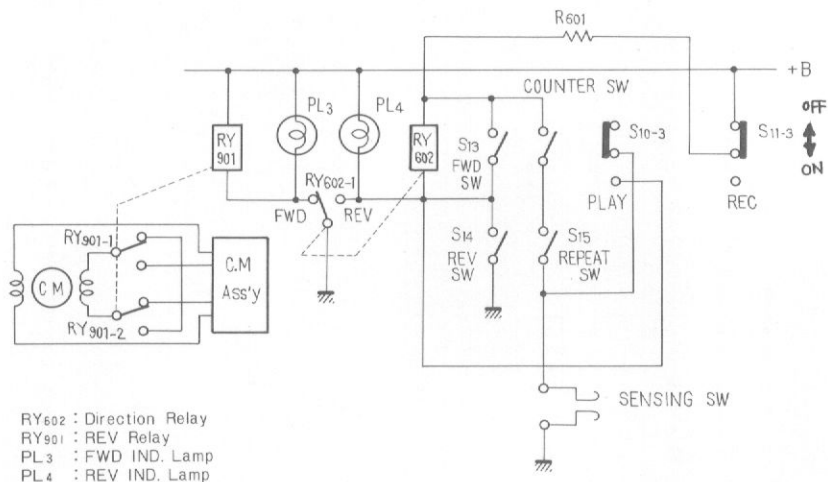

NOTE:
 The reversing relay RY₉₀₁ is located inside the capstan motor assembly.

Fig. 4

6.4 SWITCHING CIRCUIT, MUTING CIRCUIT

Fig. 5 shows the switching circuit for forward play/reverse play switchover, as well as the muting circuits operative during switchover and when the power to the unit is first turned on.

• Forward Play/Reverse Play Switching Circuit

1. +B flows along the route REV indicator lamp PL₄ → R₁₁₂ → R₁₀₇ → Q₁₀₁ → R₁₀₅ → Ground. Q₁₀₁ is in ON state, and the output from IC₁₁₀₁ enters the subsequent amplifier stage.
2. The base of Q₁₀₃ is grounded through R₁₀₉ → R₁₁₁ → direction change relay RY₆₀₂₋₂ → ground, so Q₁₀₃ is off and the output from IC₁₁₀₂ cannot enter the subsequent amplifier.

The signals from the playback heads are thus constantly amplified in head amps IC₁₁₀₁ and IC₁₁₀₂, respectively, but the signals paths are switched by Q₁₀₁, Q₁₀₂ in accordance with tape travel direction.

• Muting at Time of Tape Travel Direction Change

A muting circuit interrupts amplifier output during the time that the tape reversing its direction of travel, is not moving at the rated speed of 19 or 9.5cm/s.

1. During forward play, C₁₂₅ remains discharged through route R₁₁₁ → direction change relay RY₆₀₂₋₁ → R₁₅₄ → D₁₀₄ → ground.
2. When the travel direction is changed from forward to reverse play, +B causes a charging current to flow to C₁₂₅ through forward indicator lamp PL₃ → R₁₁₁ → C₁₂₅ → D₁₀₂ → R₁₅₆ → Q₁₁₇. Q₁₁₇ is ON, while Q₁₁₈ is OFF.
3. Consequently, the voltage drop across R₁₆₀ (which is the load on Q₁₁₈) becomes small. The positive potential at the Q₁₀₅ base (from

R₁₁₅) is cancelled out, the base obtains positive potential, and Q₁₀₅ becomes ON. By reducing the impedance between collector and emitter, the output from the IC's is muted.

4. When C₁₂₅ has been fully charged, Q₁₁₇ base current stops flowing. Voltage drop across R₁₆₀, the load on Q₁₁₈, becomes large, the base of Q₁₀₅ obtains negative potential from R₁₁₅. This increases the collector-emitter impedance of Q₁₀₅, and no muting of the IC outputs takes place.

• Muting at Time of Power Switch-on

1. When the power is switched on, current flows along the route +B (25V) → D₁₀₆ → Q₁₁₅ → R₁₆₅. A voltage appears across R₁₆₅.
2. This voltage across R₁₆₅ is applied to Q₁₁₃ through R₁₃₉, whereby Q₁₁₃'s collector-emitter impedance drops and muting of the line out signal is effected.
3. Through +B (25V) → C₁₁₉ → R₁₃₉ → Q₁₁₃, a charging current flows to C₁₁₉, resulting in a drop in Q₁₁₃ collector-emitter impedance. This means that muting by Q₁₁₃ is dependent upon the C₁₁₉ and C₁₂₁ charging currents. C₁₁₉ serves for brief muting while the power is being switched on, whereas C₁₂₁ causes approx. 3 seconds of muting after switch-on.
4. When C₁₁₉, C₁₂₁ have been charged, a negative potential builds up through R₁₄₇ → R₁₃₉ → Q₁₁₃, resulting in an impedance drop between Q₁₁₃ collector and emitter and thus ending the period of muting.

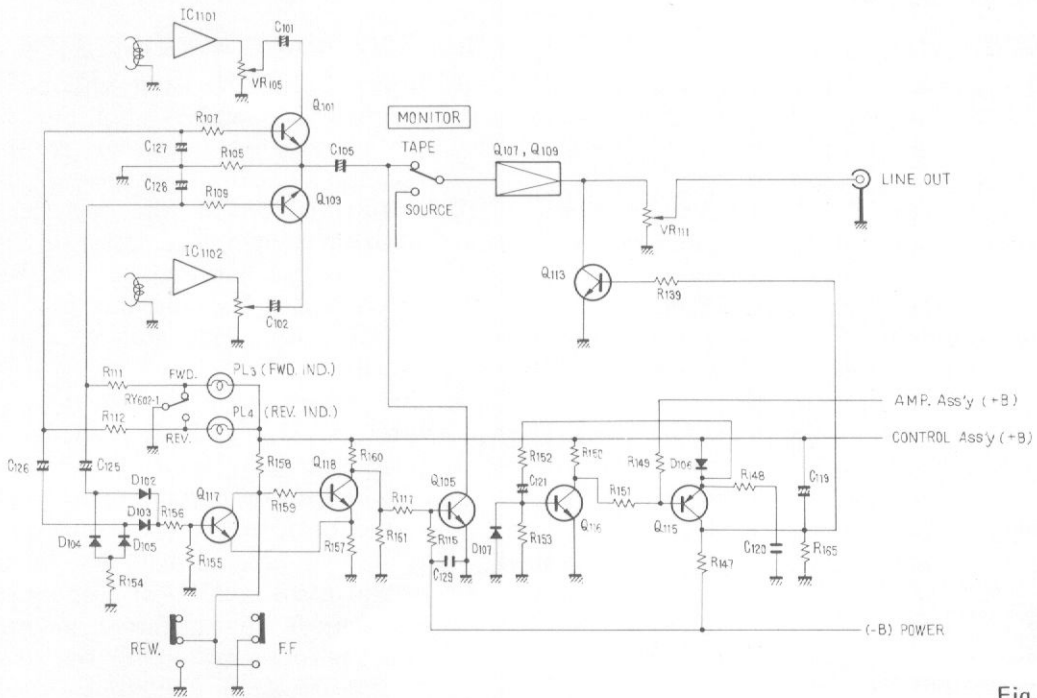

Fig. 5

6.5 PLAYBACK AMPLIFIER (Fig. 6)

1. The playback signal from the playback head enters IC₁₁₀₁ through C₁₁₀₃.
2. The amplified output from IC₁₁₀₁ undergoes playback equalization in the equalizer formed by VR₁₀₁, R₁₁₀₉, R₁₁₀₇, C₁₁₁₃.
3. The difference in equalization between 19cm and 9.5cm/s tape speeds is obtained by varying the voltage applied to the gate of FET Q₁₁₀₁ (0.4V for 19cm/s, -8.5V for 9.5cm/s) and utilizing the resultant change in the FET's internal impedance.
4. Downstream from IC₁₁₀₁, the signal path is switched by Q₁₀₁ whose function has been

explained under 7.4, Switching Circuit, Muting Circuit, above.

The signal is then amplified in the direct coupled NPN-PNP amplifier (Q₁₀₇, Q₁₀₉) and becomes available at the line output terminals.

5. A portion of the output signal undergoes impedance conversion in Q₁₁₁ and matching transformer T₁₀₁ and becomes available at the phones output jack.
6. For driving the level meters, output from Q₁₁₁ is amplified in Q₁₀₀₁ and rectified in D₁₀₀₁, D₁₀₀₃.

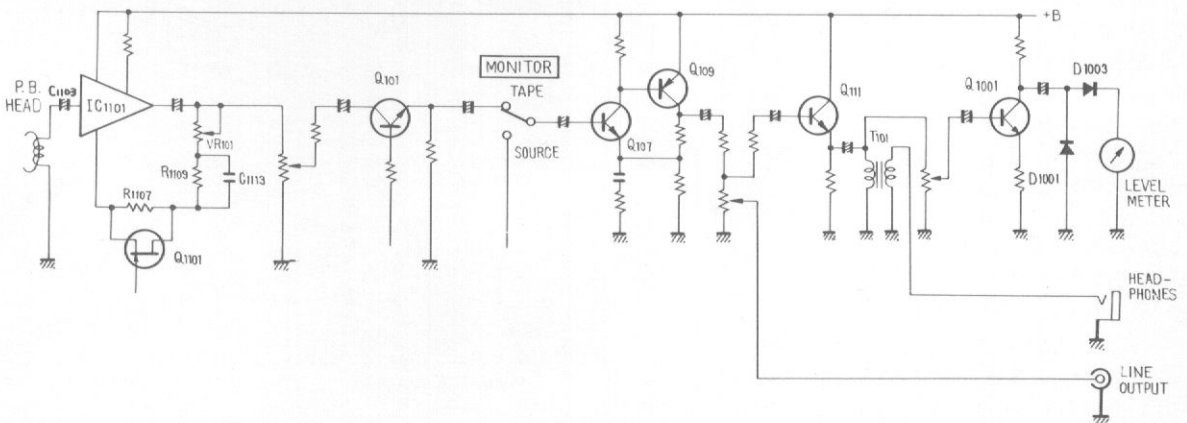

Fig. 6

6.6 BIAS OSCILLATOR (Fig. 7)

1. When +B (approx. 30V) is applied to Q₃₀₅, Q₃₀₆, a positive feedback loop is established through the oscillator transformer T₃₀₁, and oscillation begins.
2. From the secondary side of TR₃₀₁, the oscillation signal is supplied to the erase and recording heads.
3. The oscillation frequency is stabilized against temperature fluctuations by means of thermistor TH₃₀₁ which regulates the base current of Q₃₀₅, Q₃₀₆.
4. In monaural recording, the REC (L) switch S₆₋₂ or REC (R) switch S₇₋₂, respectively, is switched to a dummy coil which maintains uniform load on the oscillator, for stable operation.

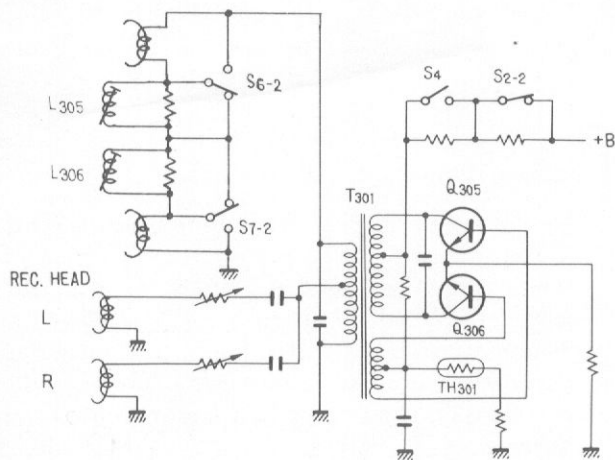

Fig. 7

6.7 RECORDING AMPLIFIER (Fig. 8)

1. Input from the microphone jacks passes through C₂₀₁ and is amplified in the 2-stage direct coupled amplifier formed by Q₂₀₁, Q₂₀₃.
2. Output from this mic head amp, after level adjustment by VR₂₀₁, enters Q₂₀₅. Line input is level adjusted in VR₂₀₃ and then enters Q₂₀₅. Mic and line inputs can thus be mixed, with independent level adjustments for each.
3. The signal, amplified in Q₂₀₅, Q₂₀₇ passes through VR₁₀₂ and enters the base of Q₃₀₁.
4. Q₃₀₁ and Q₃₀₃ serve to obtain the current required for driving the recording head. A feedback loop (Q₃₀₃ collector → R₃₁₃, C₃₀₇ → R₃₁₅ → Q₃₀₁ emitter) has been provided to obtain +4dB at 20Hz of bass equalization.
5. To achieve the different amounts of treble equalization required for the two tape speeds, a transistorized switching circuit has been included. Assuming, for instance, that low noise high output tape is being used at 19cm/s: a positive voltage is applied to the base of Q₃₀₇, its internal impedance drops, and the series resonant circuit constituted by L₃₀₁, C₃₁₃, functions.
6. From Q₃₀₃, the signal enters the recording head via L₃₀₃, C₃₂₅. L₃₀₃ and C₃₂₅ are tuned to the recording bias frequency, preventing reverse bias flow in the circuit.

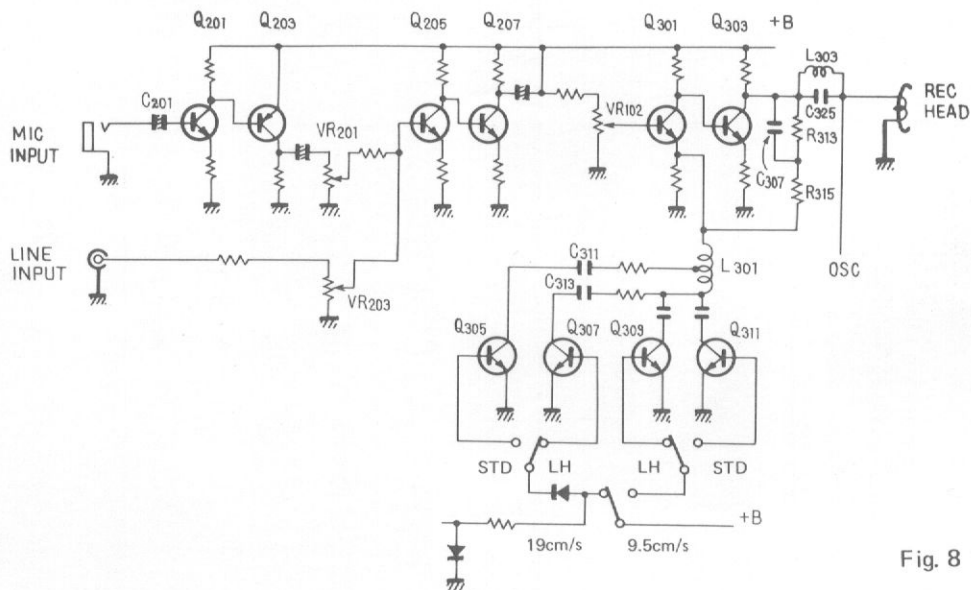

Fig. 8

6.8 FREQUENCY GENERATOR

The frequency servo generator block diagram is given in Fig. 9. For the circuit schematic, please refer to page 95.

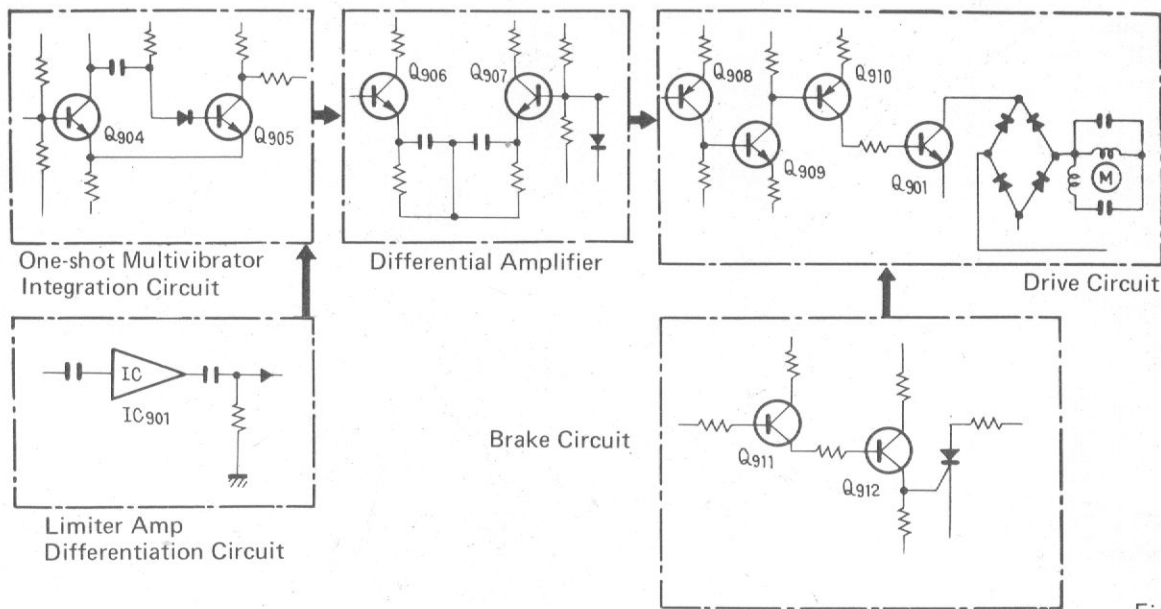

Fig. 9

The construction of the frequency generator (abbreviated FG) is shown in Fig. 11. The rotor is mounted to the flywheel and the stator, magnet and generation coil are installed to the motor bracket.

The magnetic flux from the magnet flows through the loop stator teeth ~ rotor teeth ~ magnet. When the motor rotates 1 revolution, the rotor and stator teeth alignment changes as illustrated by a and b of Fig. 10. Therefore, the amount of magnetic flux (magnetic flux density) flowing through the loop changes. An AC voltage of a frequency proportional to the number of times the magnetic flux density changes is generated in the generation coil. The output signal of this FG is approximately 1360Hz, 150mV at a tape speed of 19cm/s.

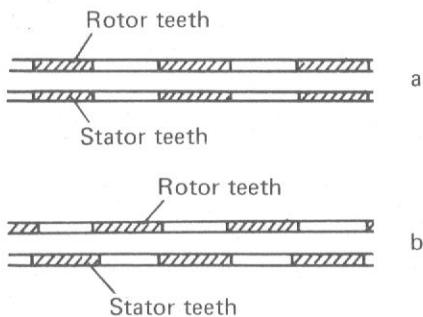

Fig. 10

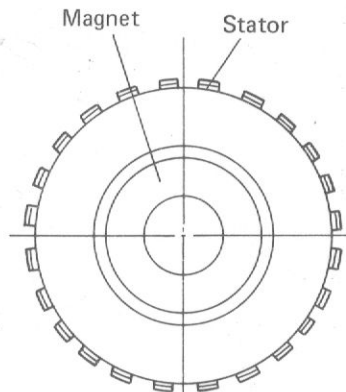
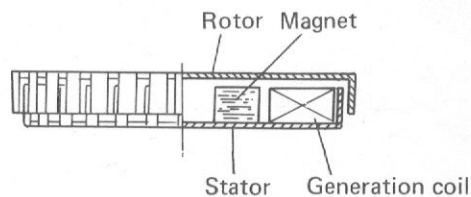

Fig. 11

● Limiter Amplifier and Differentiator Circuit

The limiter amplifier and differentiator circuit are shown in Fig. 12. The AC signal generated by the FG circuit is shaped to the square wave shown in Fig. 17-2 (Fig. 12-a) by an IC limiter amplifier.

The output of this amplifier is shaped into a pulse by a CR differentiator circuit and the positive pulse of Fig. 17-4 (Fig. 12-b) is extracted by means of a diode D.

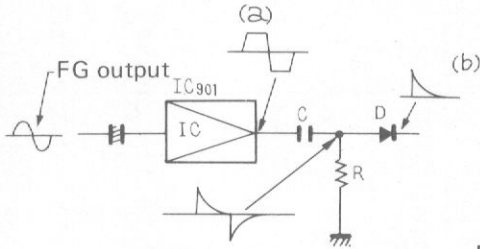

Fig. 12

● One-shot Multivibrator Circuit and Integrating Circuit (Fig. 13)

The positive pulse obtained above is used to trigger a one-shot multivibrator. When there is no input signal, Q_{904} is OFF and Q_{905} is ON and point A becomes nearly stable due to the voltage drop across R_L . However, when a positive pulse is applied to the input of the multivibrator, Q_{904} is turned ON, Q_{905} is turned OFF (Q_2 collector current doesn't flow) and the voltage of point A rises to near the power supply voltage. The multivibrator remains in this state during time T_2 determined by the time constant of C and R and then returns to its original stable state.

In short, positive square waves equal to the number of input trigger pulses are produced. When the frequency of the signal generated by the FG circuit changes (motor speed changes), the spacing T_3 of the trigger pulses also changes. Looking at this at point A, the output is different for the time interval of T_2 , output 0V as shown in Fig. 17-5.

If the output of a one-shot multivibrator is passed through an integrating circuit consisting of R_x and C_x , when the closing time of T_2 is long as illustrated in Fig. 17-6, the output of point B at which the DC has changed can be made low and the change of T_2 (change in speed) can be extracted as a DC voltage change. Moreover, the speed (tape speed) may also be changed even when T_1 is changed in a like manner. In this machine, the tape speed is adjusted by changing R.

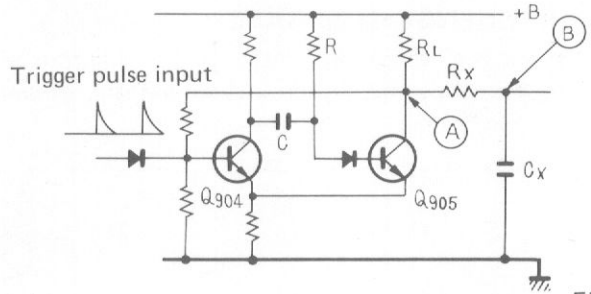

Fig. 13

● Differential Amplifier

The DC voltage ΔDC obtained at the low-pass filter circuit is applied to the differential amplifier of Fig. 14 and compared with the reference voltage. The difference between this voltage and the DC voltage obtained at the correct speed, that is, the voltage component produced by the speed error, is operated differentially.

For instance, when the motor speed is too fast, since ΔDC increases, I_{C1} increases, the voltage of point A rises, I_{C2} decreases, and ΔE_o also decreases. This ΔE_o is sent to the drive circuit.

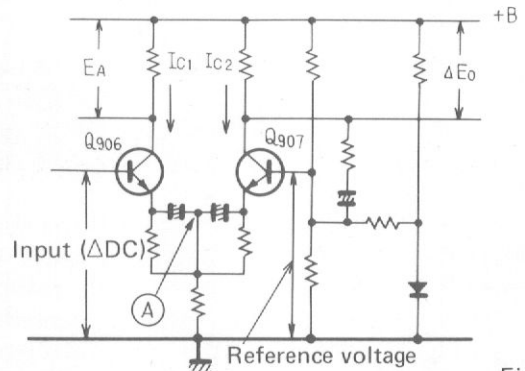

Fig. 14

● Drive Circuit

The drive circuit is shown in Fig. 15.

ΔE_o of the differential amplifier is the input of Q_{908} . When ΔE_o is reduced (that is, when the speed of the motor is fast), the collector current of Q_{908} , Q_{909} and Q_{910} is reduced until, finally, the internal resistance of Q_{901} increases.

When point A has become positive, the current path from the AC input is through the route A → motor winding → D_{901-2} → Q_{901} → D_{901-3} → B and when point B has become positive it is through the route B → D_{901-1} → Q_{901} → D_{901-4} → motor winding → A. The increase in the internal resistance of Q_{901} causes the motor current winding current to decrease and the motor speed decreases and is returned to an accurate speed.

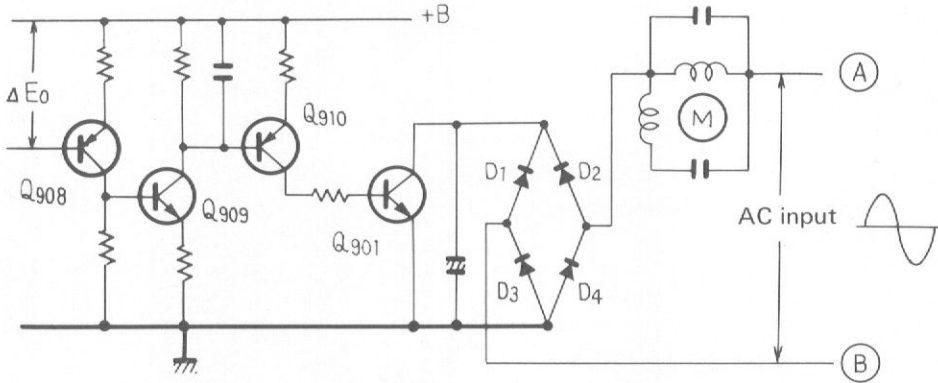

Fig. 15

● Brake Circuit

The brake circuit is shown in Fig. 16. Input E_A of Q_{911} is the collector output of the differential amplifier Q_{907} (Fig. 14). Voltage E_B of point a is set by R_A , R_B so that it is higher than E_A at the rated speed. Consequently, Q_{911} , Q_{912} and the SCR are turned OFF and the brake is not operated.

If it is assumed that the tape speed has been switched from 19cm/s to 9.5cm/s, for example, the servo circuit detects the change in speed. The internal resistance of Q_{901} of Fig. 15 increases, the motor winding current decreases and the motor speed decreases. Since the motor is unloaded if the function switch on the tape deck is set to a position other than PLAY (REC) at this time, it is rotated by the inertial energy of the flywheel and the rated speed is not reached immediately (this machine requires about 10 seconds to reach the

rated speed). The increase of E_A when the speed has deviated to the high side as described in the "Differential amplifier" section is utilized to improve on this. When $E_A > E_B$, Q_{911} , Q_{912} and SCR are turned ON, DC (pulsating) flows in the motor winding and the magnetic brake is applied to the motor and the time required for the motor to drop to the rated speed is shortened.

The brake current flows through the following route:

When point A of the AC input has become positive: A → motor main coil → motor auxiliary coil → R_c → SCR → D_{901-3} → B

When point B has become positive, the SCR acts as a diode and reverse current doesn't flow and brake current doesn't flow.

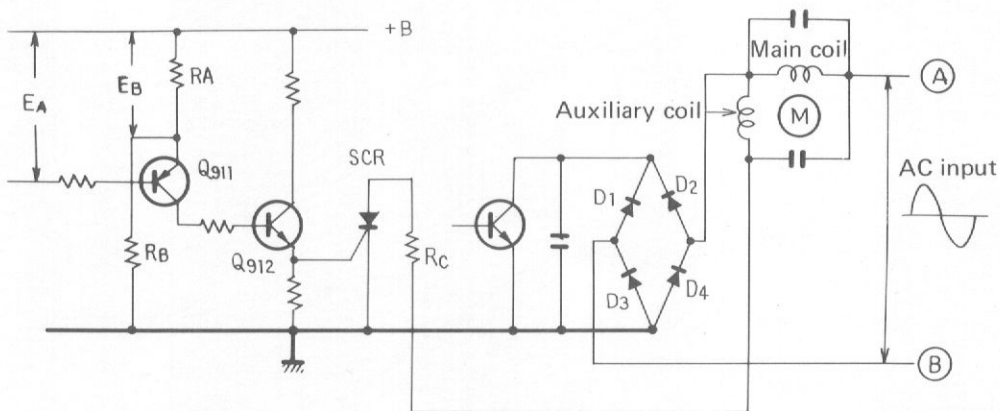

Fig. 16

Frequency too low
(Rotation too slow)

Frequency too high
(Rotation too fast)

Fig. 17-1 FG Output

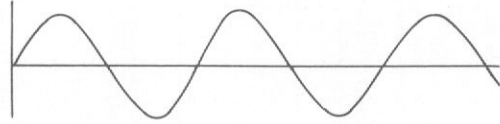
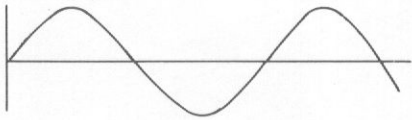

Fig. 17-2 Limiter Output

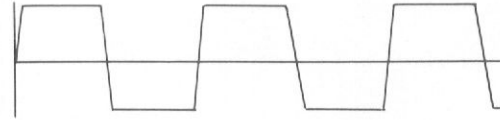
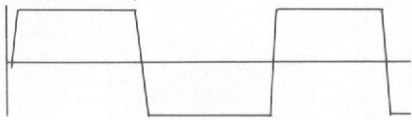

Fig. 17-3 Differentiator Output

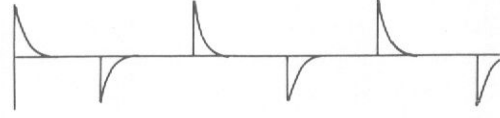
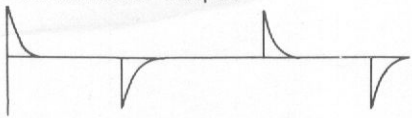

Fig. 17-4 Trigger Input

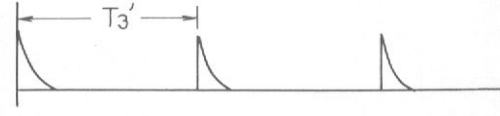
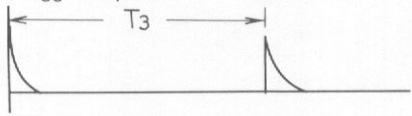

Fig. 17-5 One-shot Multivibrator Output

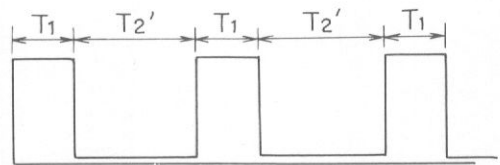
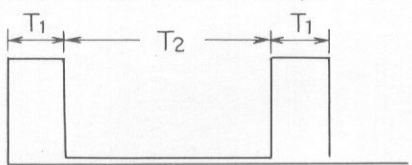

Fig. 17-6 Integrator Output

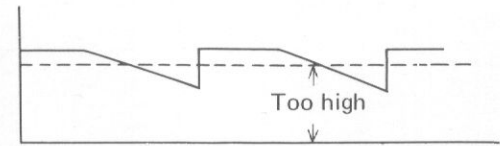
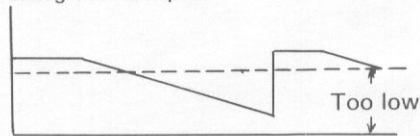

Fig. 17

7. DISASSEMBLY

7.1 BONNET

Remove the screws 1 ~ 8 on the each side of the bonnet, then remove the screws 9 ~ 10 as shown in Fig. 18.

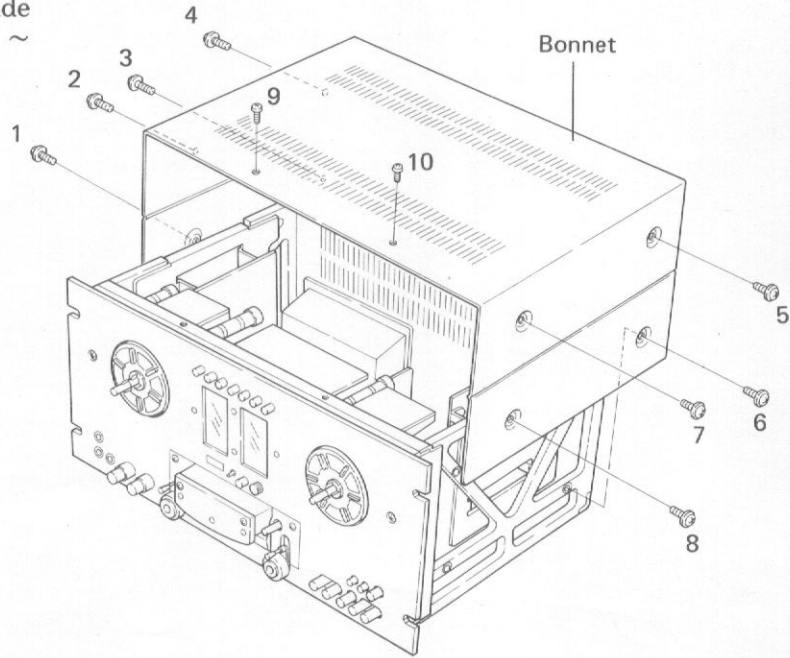

Fig. 18

7.2 REAR PANEL

Remove the screws 1 ~ 9 to detach the rear panel, then remove the screw 10 for ground as shown in Fig. 19.

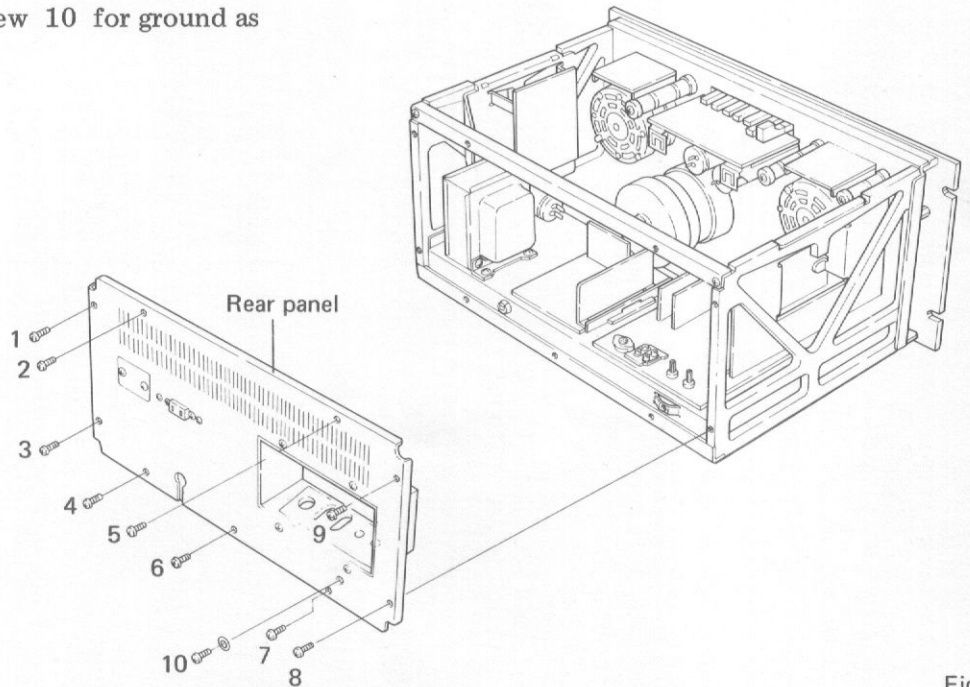

Fig. 19

7.3 BOTTOM PLATE

Remove the screws 1 ~ 10 to detach the bottom panel as shown in Fig. 20.

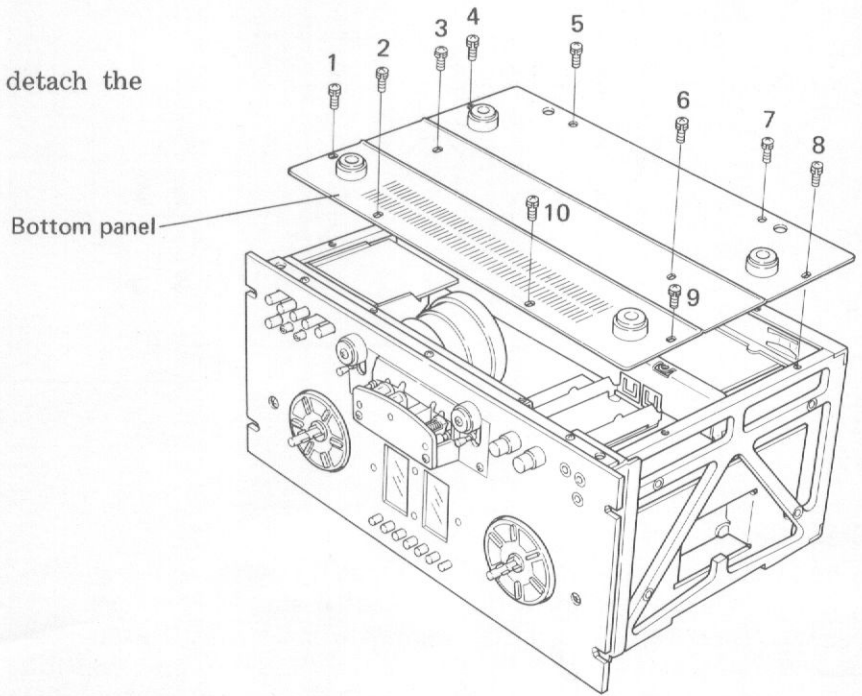

Fig. 20

7.4 FRONT PANEL

1. Pull off the knobs (MIC, INPUT and PITCH CONTROL).
2. Remove the screws 1 ~ 5 to detach the front panel.

NOTES:

- Hook a rubber band as illustrated in Fig. 21 and remove the front panel without remove the tension roller.
- After removing the front panel, misalignment and scratching of the meter can be prevented by hooking a rubber band to the level meter as illustrated in Fig. 21 (at reel base height adjustment, brake adjustment, etc).

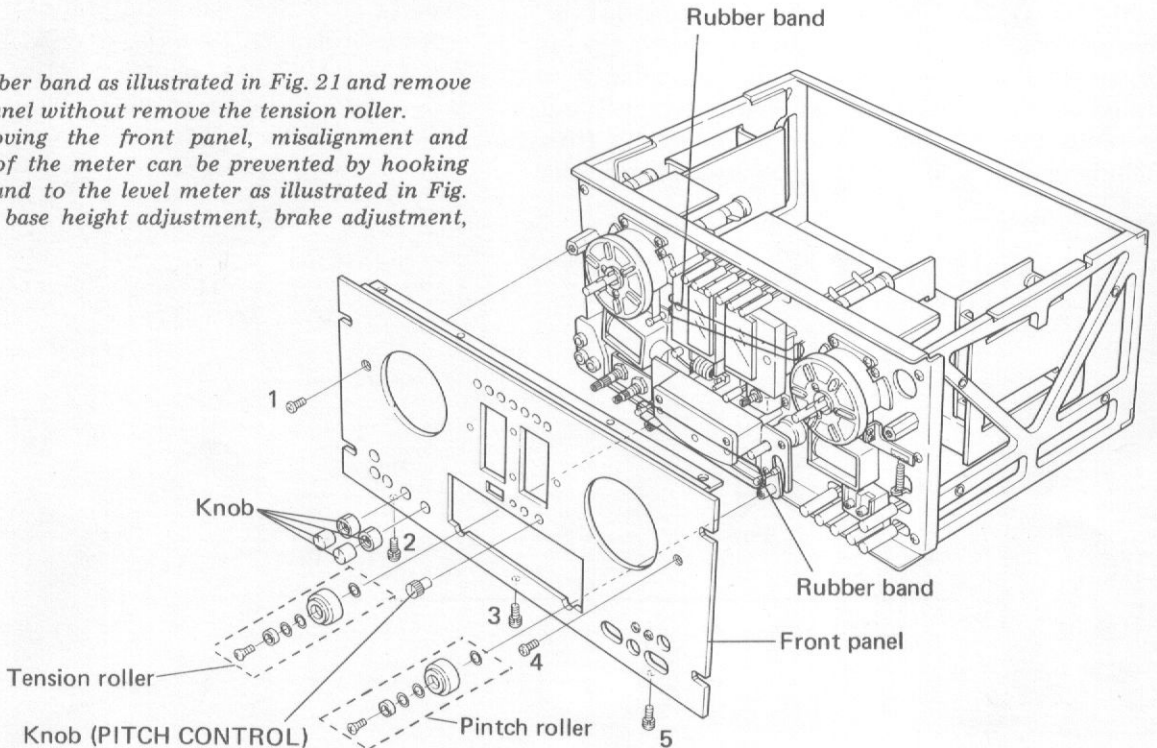
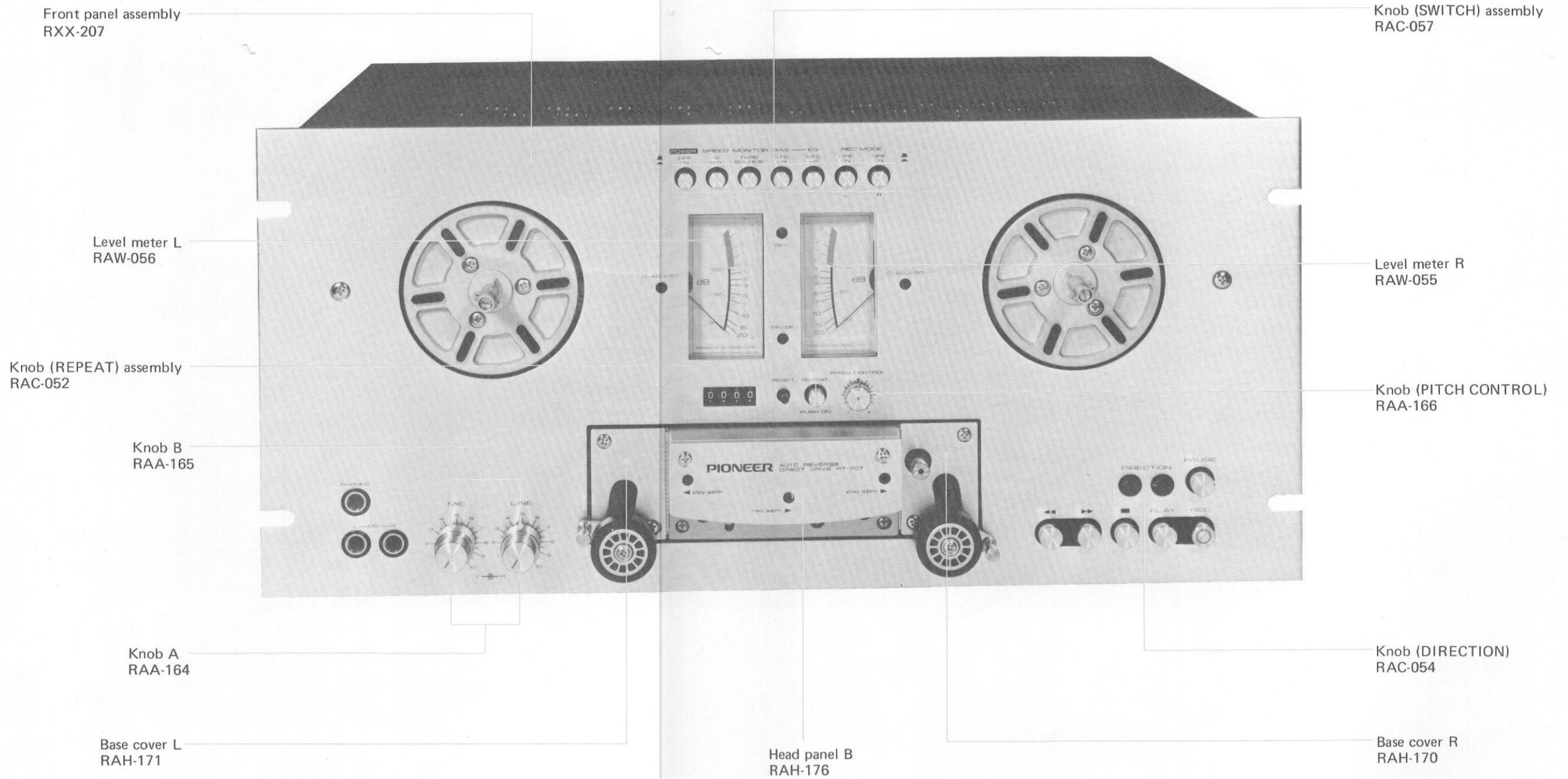

Fig. 21

8. PARTS LOCATIONS

8.1 FRONT PANEL VIEW



8.2 FRONT VIEW WITH FRONT PANEL REMOVED

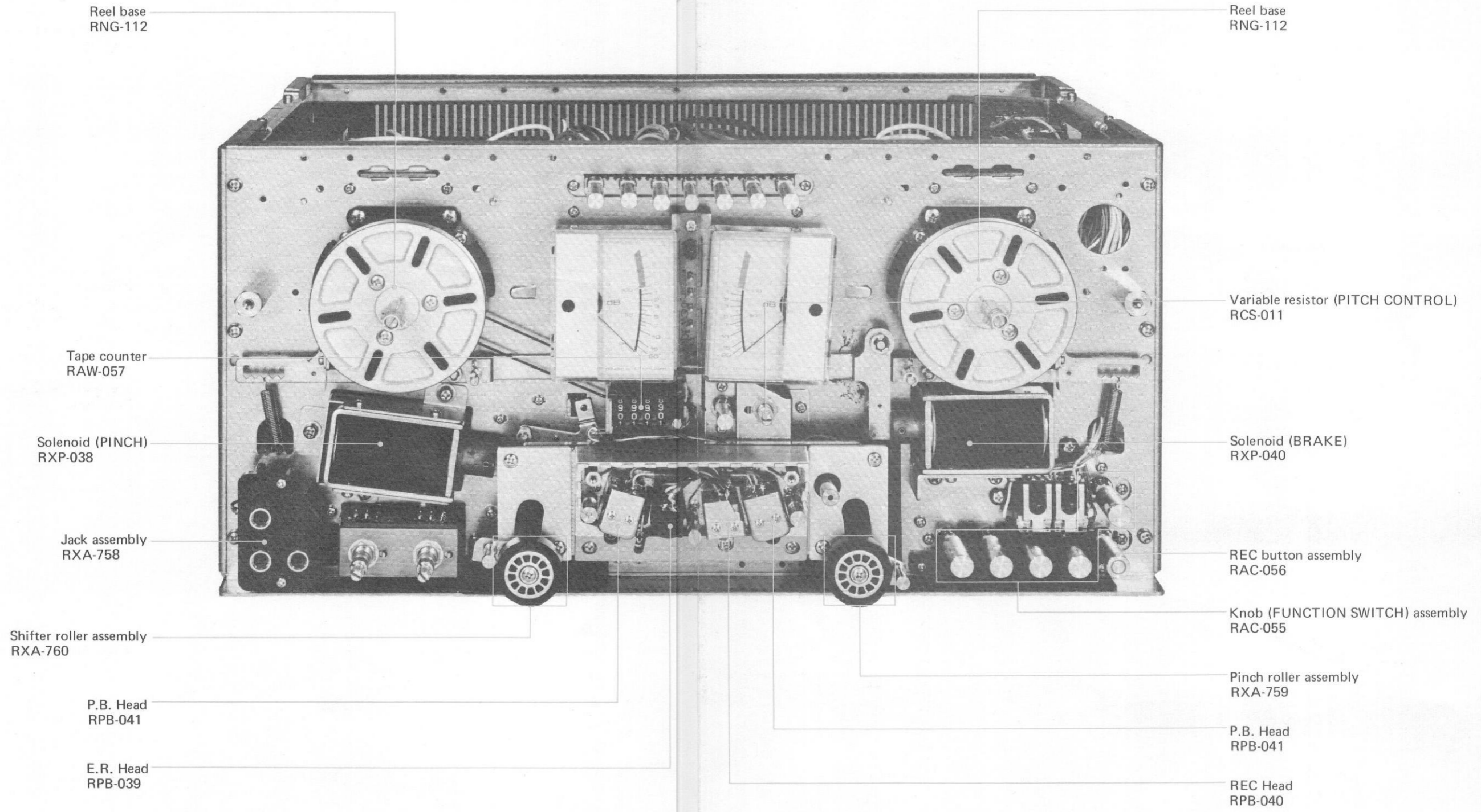

8.3 TOP VIEW WITH BONNET REMOVED

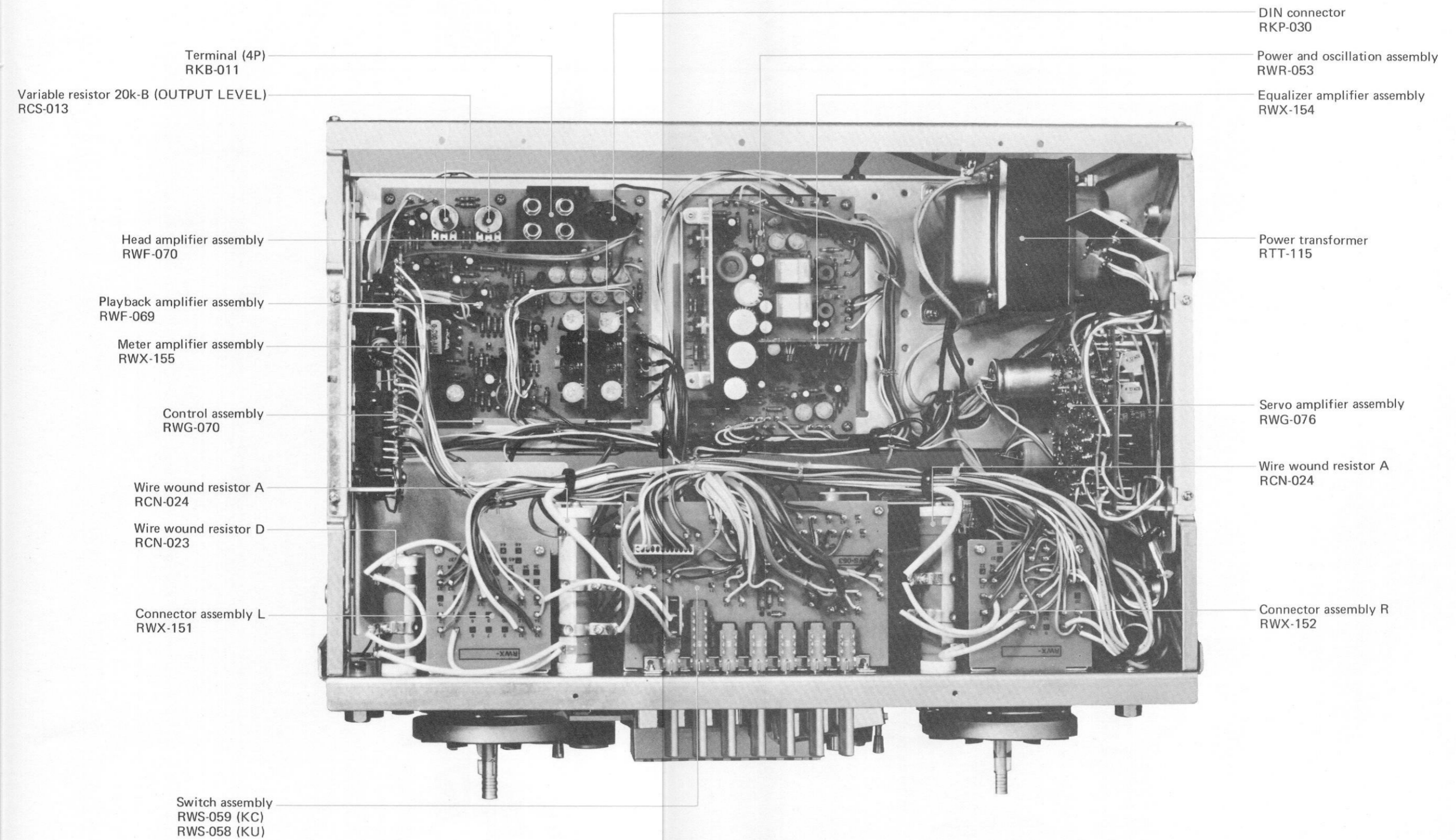

Terminal (4P)
RKB-011

Variable resistor 20k-B (OUTPUT LEVEL)
RCS-013

Head amplifier assembly
RWF-070

Playback amplifier assembly
RWF-069

Meter amplifier assembly
RWX-155

Control assembly
RWG-070

Wire wound resistor A
RCN-024

Wire wound resistor D
RCN-023

Connector assembly L
RWX-151

Switch assembly
RWS-059 (KC)
RWS-058 (KU)

DIN connector
RKP-030

Power and oscillation assembly
RWR-053

Equalizer amplifier assembly
RWX-154

Power transformer
RTT-115

Servo amplifier assembly
RWG-076

Wire wound resistor A
RCN-024

Connector assembly R
RWX-152

8.4 BOTTOM VIEW WITH BOTTOM PANEL REMOVED

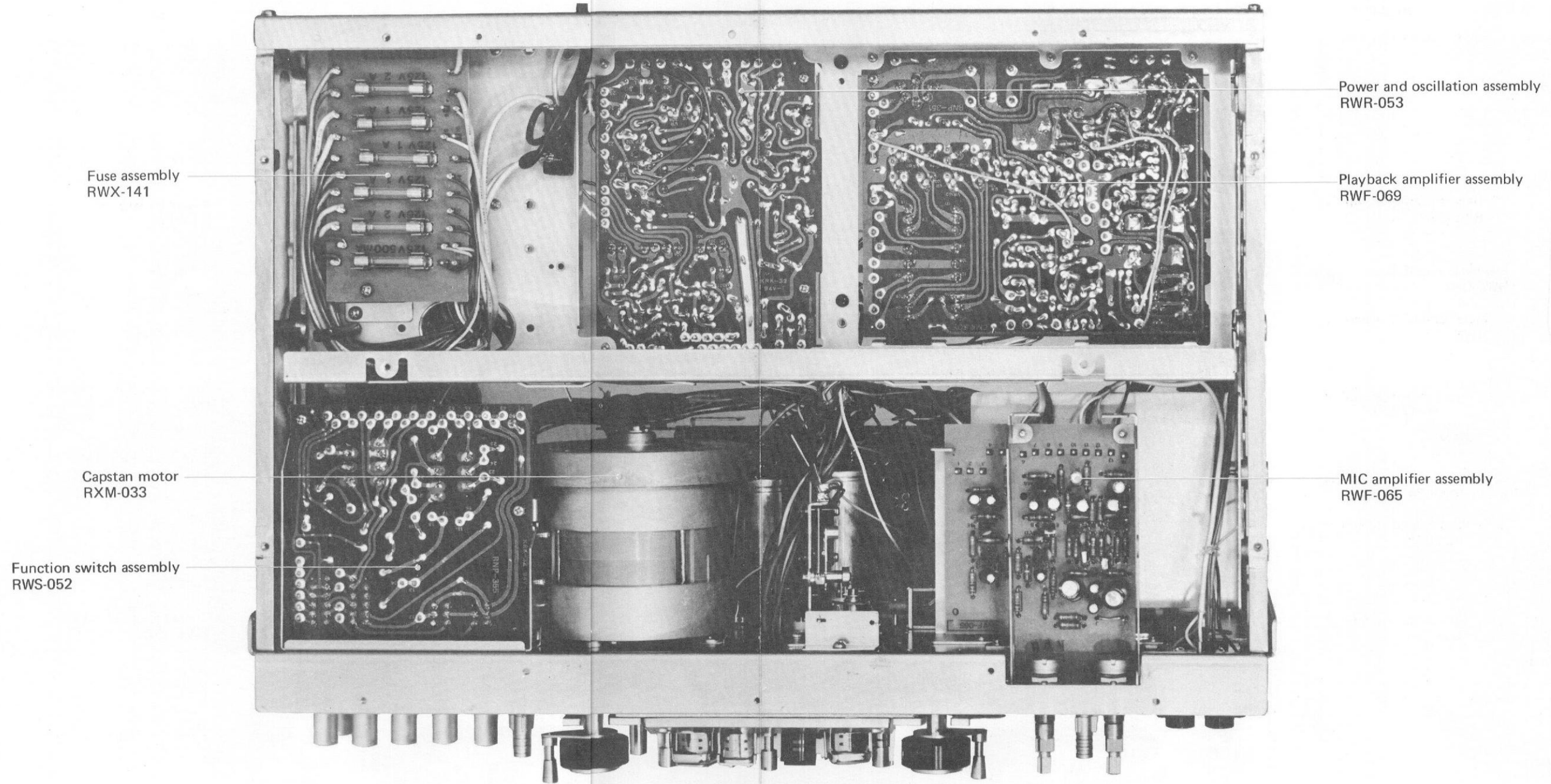

8.5 REAR PANEL VIEW

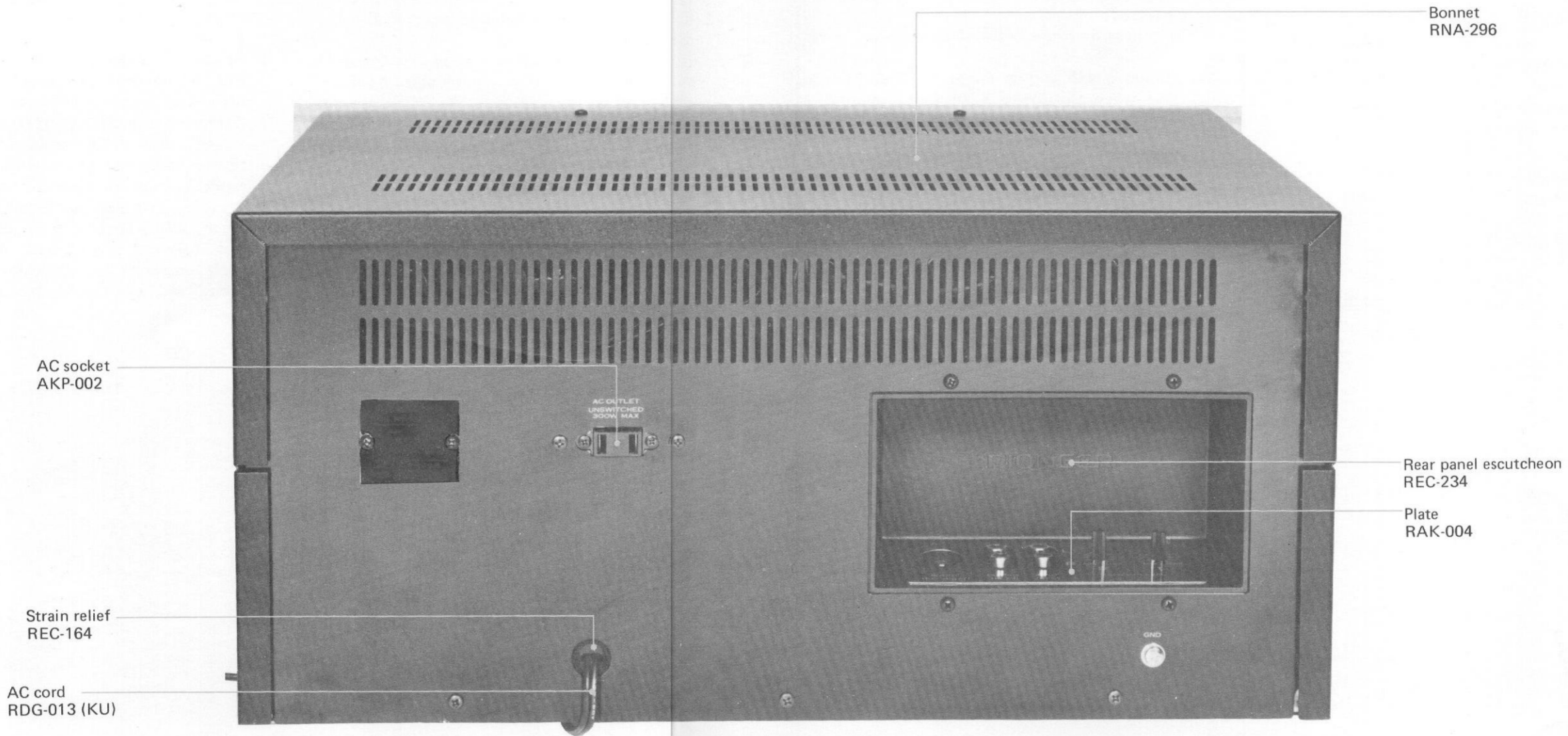

Bonnet
RNA-296

AC socket
AKP-002

Rear panel escutcheon
REC-234

Plate
RAK-004

Strain relief
REC-164

AC cord
RDG-013 (KU)

9. MECHANICAL ADJUSTMENTS

● Perform adjustments in the vertical position unless otherwise specified.

9.1 REEL BASE HEIGHT ADJUSTMENT

This adjustment is necessary when the height of the reel base is unsuitable and when the supply motor or takeup motor has been replaced.

1. Remove the bonnet and front panel (see page 21) then place the tape deck in the horizontal position.
2. Loosen and adjust the set screw with an allen wrench as illustrated in Fig. 22 so that the clearance between the mechanism and brake drum becomes $25.4\text{mm} \pm 0.15\text{mm}$.
3. This adjustment is performed in the same manner at both the supply reel base and takeup reel base. After adjustment, retighten the set screw.

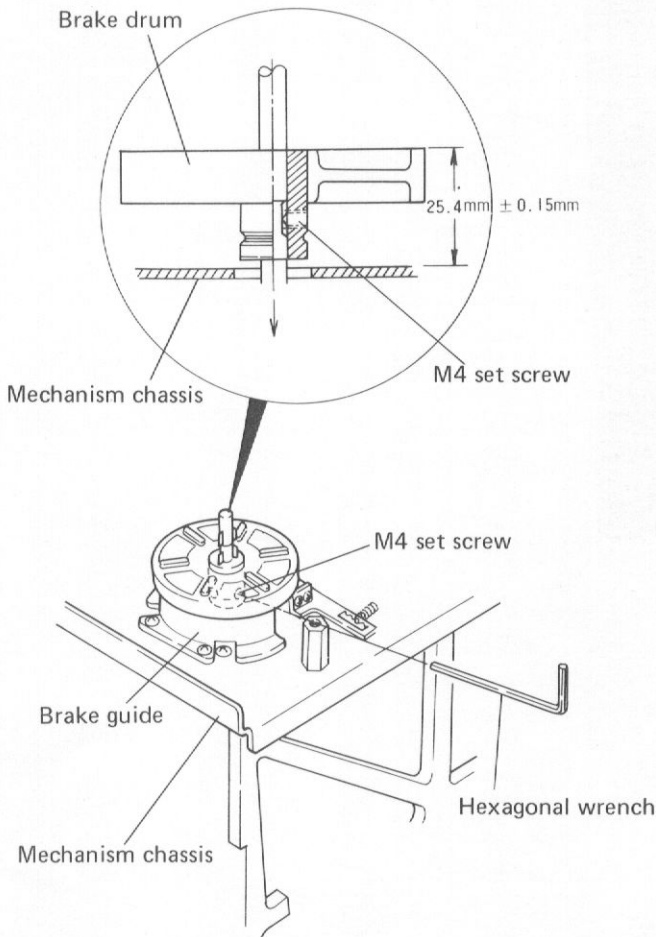

Fig. 22

9.2 BRAKE ADJUSTMENT

This adjustment must be performed when the brake solenoid or motor has been replaced or when the tape is abnormally tight or loose when the tape has been stopped.

Check the following items before beginning adjustment:

1. Are dimensions ① and ② shown in Fig. 24 as specified when the brake is applied (solenoid attracted)? When outside the specified dimensions, loosen and readjust the M2.6 screw.
2. Is the brake guide mounted so that the brake drum and brake felt are uniformly separated when the brake is released (when the shaft of the solenoid is pushed by hand) after the check of item 1 above?

If the motor does not rotate smoothly when turned by hand, loosen the screw mounting the brake guide and adjust the guide mounting position.

● Adjustment Procedure

1. Set the tape deck to the STOP state.
Fasten a piece of string to a No. 7 reel (hub diameter 60mm) and place the reel onto the reel base (Fig. 23).
2. Hook a tension gauge to the end of the string and pull in direction B (C) and read the value indicated at the tension gauge when the reel base begins to turn.
3. Adjust the hooking position of the brake spring shown in Fig. 24 so that this value becomes 300 ~ 400g (torque = 900g.cm ~ 1200g.cm).
4. If the specified value cannot be obtained by changing the hooking position of the brake spring, check for the following:
 - a) Brake drum dirty
 - b) Brake felt dirty
 - c) Brake guide mispositioned
 - d) Brake arm operation not smooth
5. Confirm that the following relation is established between the above measured value and the value measured when the tension gauge is pulled in direction (A) D.

$$\begin{aligned} \text{Brake ratio} &= \frac{\text{Direction B (C) measured value}}{\text{Direction (A) D measured value}} \\ &= 1.7 \sim 2.3 \end{aligned}$$

9.3 TAKEUP TORQUE, BACK TENSION

● Back Tension Torque Adjustment at PLAY

1. Forward playback at a set tape speed of 19cm/s and measure the back tension of the supply side reel base (Pull the gauge in direction B of Fig. 23).
2. Adjust the slider (R_{3-1}) of sliding resistor R_3 shown in Fig. 25 so that the measured value becomes 70 ~ 80g (torque = 210g.cm ~ 240g.cm).
3. Reverse playback at a set tape speed of 19cm/s and measure the back tension of the supply side reel base (Pull the gauge in direction C of Fig. 23).
4. Adjust the slider (R_{2-1}) of sliding resistor R_2 in Fig. 25 so that the measured value becomes 70 ~ 80g (torque = 210g.cm ~ 240g.cm).
5. After adjustment, securely retighten the slider (R_{3-1}) screw.

● Takeup Torque Adjustment at PLAY

1. Forward playback at a set tape speed of 19cm/s and measure the takeup tension of the takeup side reel base (Pull the tension gauge in the C' direction of Fig. 23).
2. Adjust the slider (R_{2-2}) of sliding resistor R_2 shown in Fig. 25 so that the measured value becomes 125 ~ 135g (torque = 375g.cm ~ 405g.cm).
3. Reverse playback at a set tape speed of 19cm/s and measure the take up tension of the takeup side reel base (Pull the tension gauge in the direction B' of Fig. 23).
4. Adjust the slider (R_{3-2}) of sliding resistor R_3 shown in Fig. 25 so that the measured value becomes 140 ~ 160g (torque = 420g.cm ~ 480g.cm).
5. After adjustment, securely retighten the slider screw.

● Rewind Back Tension Torque Adjustment

1. Operate the set at rewind and measure the back tension of the supply side reel base. (Pull the tension gauge in the C direction of Fig. 23).
 2. Adjust the slider of ^{*}sliding resistor R_1 shown in Fig. 25 so that the measured value becomes 35 ~ 45g (torque = 105g.cm ~ 135g.cm).
 3. After adjustment, securely retighten the slider screw. Since sliding resistor R_1 is also used in rewind adjustment, the rewind back tension is automatically determined when the fast forward back tension has been adjusted.
- * Since sliding resistor R_1 is also used in rewind fast forward adjustment, the fast forward back tension is automatically determined when the rewind back tension has been adjusted.

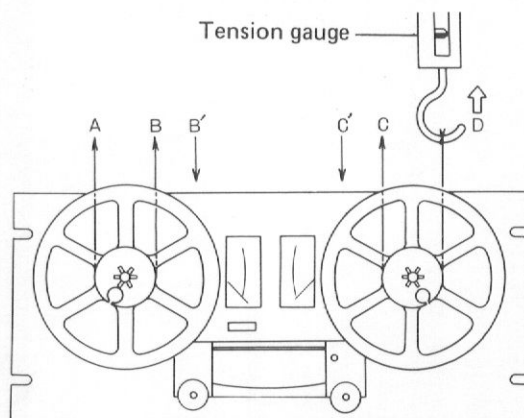

Fig. 23

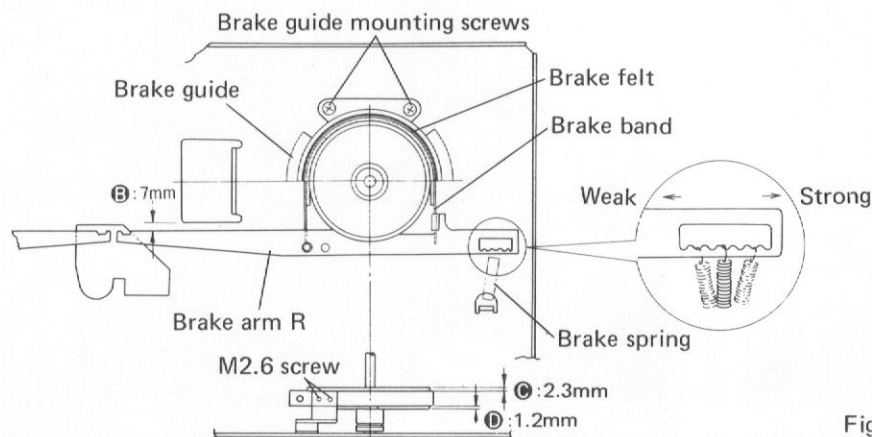

Fig. 24

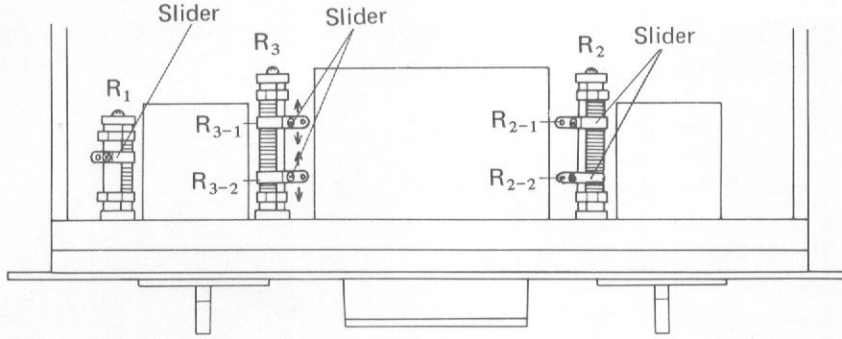

Fig. 25

9.4 PINCH ROLLER PRESSURE ADJUSTMENT

When the pinch solenoid or pinch roller has been replaced, adjust the pinch pressure as follows:

1. Playback at a set tape speed of 19cm/s and confirm that A of the pinch pressure spring shown in Fig. 27 is within 0.7mm.
2. If outside this value, loosen the 3 screws fastening the solenoid bracket and adjust the position of the bracket.
3. Load a tape, and run it at fast forward until the same amount of tape is wound on both the supply reel and takeup reel.
4. Hook a tension gauge to the pinch roller and confirm that the tape is stopped within a range of 1.3 ~ 1.6kg (Fig. 26).
5. If the tape isn't stopped within the 1.3 ~ 1.6kg range, check for the following:
 - a) Pinch pressure spring tightening faulty
 - b) Pinch pressure spring faulty
 - c) Pinch roller dirty
 - d) Capstan dirty

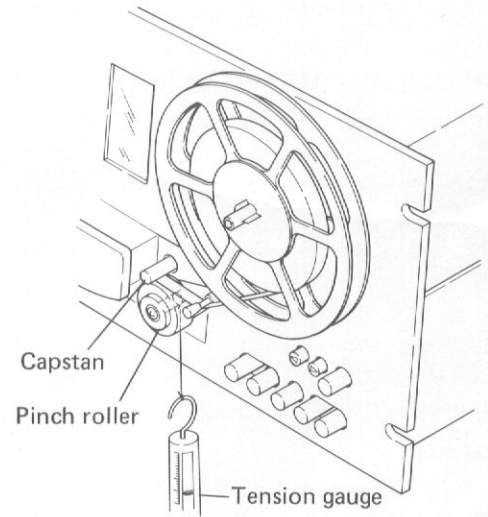

Fig. 26

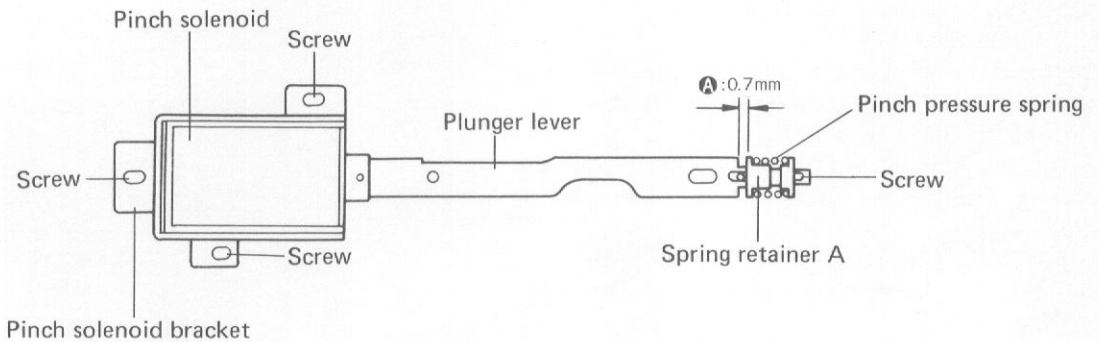

Fig. 27

9.5 PAUSE ADJUSTMENT

- Perform PAUSE adjustment after pinch pressure adjustment is complete.

1. Operate the set at playback and loosen the PAUSE solenoid set screw and adjust the solenoid position so that the clearance **A** between the PAUSE adjuster and PAUSE arm ass'y in Fig. 28 becomes 0.1 ~ 0.3mm.

2. Next, set the PAUSE switch to the ON position.

Loosen the PAUSE adjuster set screw and adjust the position of the adjuster so that the clearance **B** between the capstan shaft and pinch roller becomes 1.5 ~ 2.0mm at this time.

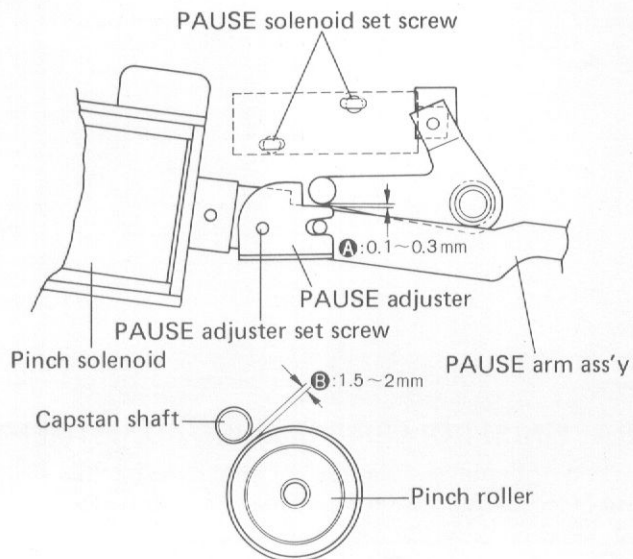

Fig. 28

9.6 TAPE SPEED ADJUSTMENT

Perform the following before beginning adjustment:

1. Set the pitch control to the center click position.
2. Wipe the capstan shaft and pinch roller off with absolute alcohol.
3. Mount the same size reel at the supply side and takeup side.
4. Check the takeup torque, back tension torque and pinch pressure.

● Adjustment

19cm/s tape speed

1. Playback the wow and tape speed measurement standard tape STD-101 until the same amount of tape is wound on the supply reel and takeup reel and measure the frequency with a frequency counter.
2. Adjust VR₂ (2k Ω) of the Servo amp ass'y of Fig. 29 so that this value becomes 3,000Hz/s.

9.5cm/s tape speed

1. Playback the wow and tape speed measurement standard tape STD-101 until about the same amount of tape is wound on the supply reel and takeup reel and measure the frequency with a frequency counter, the same as at 19cm/s.
2. Adjust VR₃ (2k Ω) in the Servo amp ass'y of Fig. 29 so that this frequency becomes 1,500Hz/s.

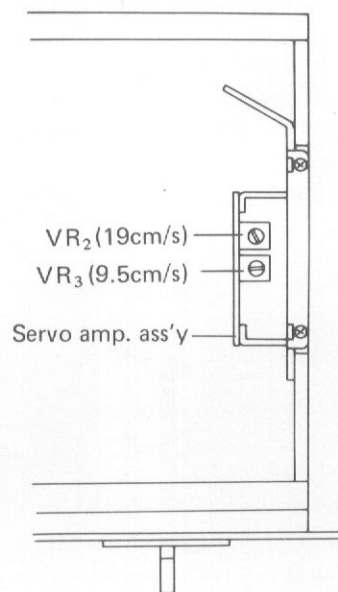

Fig. 29

10. HEAD ADJUSTMENTS

Before beginning head adjustment:

- Clean the head and demagnetize the head with a head-eraser.
- The following test equipment are necessary in head adjustment and electrical circuit adjustment.
 1. AC voltmeter (millivoltmeter) x 2
 2. Oscilloscope
 3. Audio frequency generator
 4. Frequency counter
 5. STD-154 (play system adjustment tape)
 6. STD-502 (record/play general adjustment tape)

- Use all the specified measurement tapes.
- Position the switches as follows unless otherwise specified:

Tape speed	19cm/s
BIAS switch	STD
EQ switch	STD
MONITOR switch	TAPE
MODE switch	STEREO REC
Playback control	Center click
- Make the level at measurement 0dBv=1V and connect a 50kΩ (47~51kΩ) dummy resistor to the LINE OUTPUT terminals.

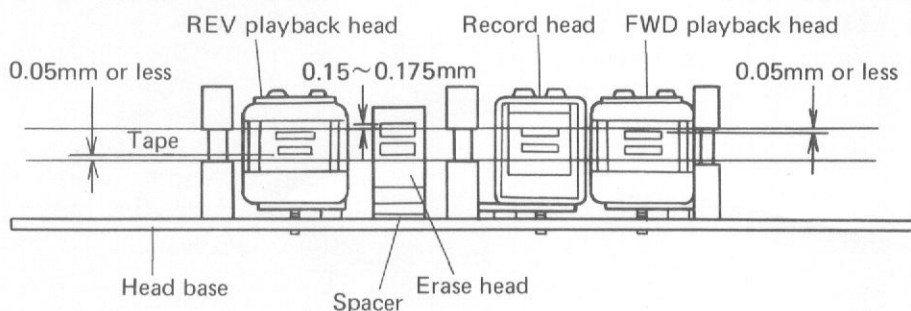

Fig. 30

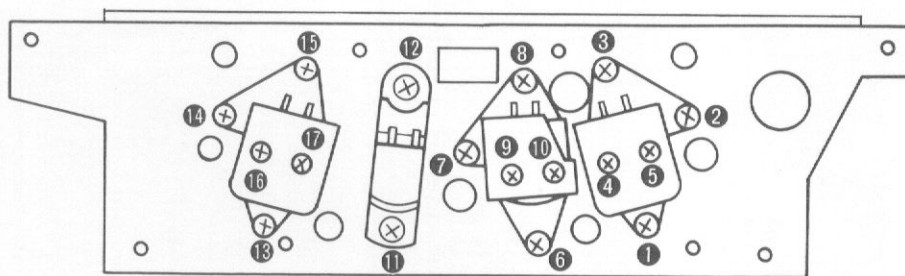

Fig. 31

10.1 HEAD ROUGH ADJUSTMENT

• HEIGHT Adjustment

Adjust the screws of Fig. 31 so that the heads and tape become the dimensions shown in Fig. 30 when the tape has been run.

- | | |
|-------------------|------------|
| FWD playback head | 1, 2, 3 |
| REV playback head | 13, 14, 15 |
| Record head | 6, 7, 8 |
| Erase head | * 11, * 12 |

*When the height of the erase head is not the dimension given in Fig. 30, loosen screws 11, 12 and adjust the height by inserting an adjustment spacer under the head.

- | | |
|-----------------|---------|
| Spacer A (0.1t) | RNF-077 |
| Spacer B (0.2t) | RNF-078 |

• TILT Adjustment

Adjust the screws of Fig. 31 so that the top and bottom of the front of the head contact the tape uniformly when the tape is running.

- | | |
|-------------------|--------|
| FWD playback head | 1, 3 |
| REV playback head | 13, 15 |
| Record head | 6, 8 |

• AZIMUTH Adjustment

Adjust the screws of Fig. 31 so that the head gaps are at right angles to the tape.

- | | |
|-------------------|----|
| FWD playback head | 2 |
| REV playback head | 14 |
| Record head | 7 |

10.2 PLAYBACK HEAD ADJUSTMENT

- Connect a voltmeter (millivoltmeter) to the LINE OUTPUT terminals (Fig. 32).
- Run the angle standard signal 15kHz of test tape STD-154 at 19cm/s.

• FWD PLAY (REV PLAY)

1. Adjust screw ② (REV PLAY ... ⑭) of Fig. 31 for maximum output level at both the L and R channels. The difference in the L and R channels output does not require attention unless it is too large.
2. When the output difference is excessive, loosen screws ④, ⑤ (REV PLAY... ⑰, ⑱) and determine the optimum position while turning the head within the horizontal plane (left, right).

10.3 RECORD HEAD ADJUSTMENT

- After the playback head has been adjusted, apply a 1kHz signal to the LINE INPUT terminals.
- Simultaneous record/play on test tape STD-502 (Fig. 32).

1. Adjust screws ⑥, ⑦, and ⑧ of Fig. 30 for maximum R channel output level at the voltmeter (millivoltmeter) connected to the LINE OUTPUT terminals.
2. Next, apply a 15kHz signal, set to the simultaneous record/play mode and fine adjust screw ⑦ of Fig. 30 for maximum L and R channel output.
3. Confirm that the output does not change even when the front of the head is pushed lightly with your finger while the tape is running.
4. When there is a difference in the L and R channel output, loosen screws ⑨, ⑩ of Fig. 30 and determine the optimum position while turning the head in the horizontal plane (left, right).

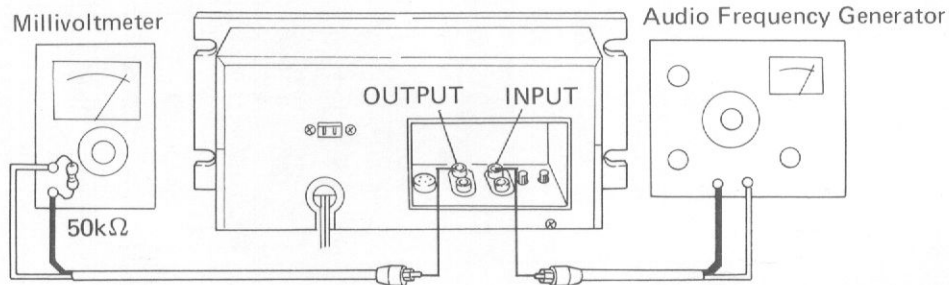
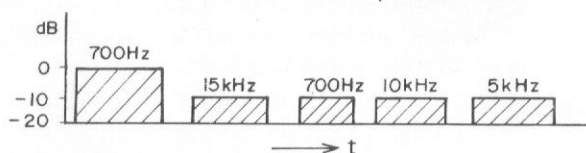

Fig. 32

11. ELECTRICAL ADJUSTMENTS

- Confirm that head adjustments and mechanism adjustments have been performed correctly before attempting to adjust the electrical circuit.
- Always perform adjustment in the below order. The rated values will not be satisfied if any adjustment items are skipped.
 1. Head adjustment (page 37).
 2. Playback level
 3. Playback EQ adjustment
 4. Level meter 0 VU adjustment
 5. Bias trap adjustment
 6. Recording bias adjustment
 7. Record/playback frequency adjustment
 8. Recording level adjustment
- Adjustment points are shown in page 41 (PHOTO 1).

Recorded Contents of Tape STD-154



11.1 PLAYBACK LEVEL ADJUSTMENT

- Connect a voltmeter (millivoltmeter) to the LINE OUTPUT terminals (Fig. 33).
- Playback the reference level setting signal 700Hz 0dB zone of test tape STD-154.

• FWD Playback (REV Playback)

1. Adjust semifixed resistors VR_{105} (L ch), VR_{106} (R ch), [REV playback... VR_{107} (L ch), VR_{108} (R ch)] for a voltmeter reading of -7dBv (450mV).

11.2 PLAYBACK EQUALIZER ADJUSTMENT

- Connect a voltmeter (millivoltmeter) to the LINE OUTPUT terminals (Fig. 33).
- Playback the reference level signal 700Hz -10dB and 10kHz -10dB of test tape STD-154.

• FWD Playback

1. Adjust semifixed resistors VR_{101} (Lch), VR_{102} (R ch) for a voltmeter (millivoltmeter) reading deviation of $0 \pm 0.5\text{dB}$.

• REV Playback

1. Adjust semifixed resistors VR_{103} (L ch), VR_{104} (R ch) for a voltmeter (millivoltmeter) reading deviation of $0 \pm 0.5\text{dB}$.

NOTE:

Since VR_{101} (VR_{103}) and VR_{105} (VR_{107}), and VR_{102} (VR_{104}) and VR_{106} (VR_{108}) effect each other, repeat adjustment several times.

11.3 LEVEL METER 0 VU ADJUSTMENT

- Connect a voltmeter (millivoltmeter) to the LINE OUTPUT terminals (Fig. 33).
- Apply a 1kHz signal to the LINE INPUT terminals and set the MONITOR switch to the SOURCE position.

1. Adjust the LINE input control so that the voltmeter (millivoltmeter) reads -7dBv (450mV).
2. At this time, adjust VR_{109} (L ch), VR_{110} (R ch) so that the level meter indicates "0".

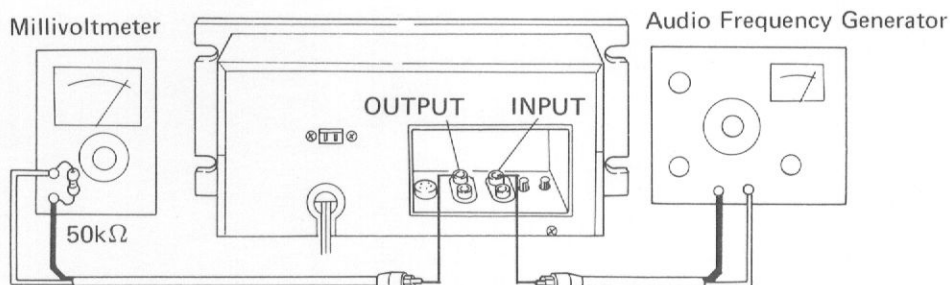

Fig. 33

11.4 DUMMY COIL ADJUSTMENT

1. Connect an oscilloscope or frequency counter to the L (R) channel side of the record head through a 2 ~ 5pF capacitor (Fig. 34).
2. Set the deck to the stereo recording state and observe the waveform on the oscilloscope. (Directly read the frequency when a frequency counter is used.)
3. Push the L (R) side MODE switch. Adjust the dummy coil L_{305} (L_{306}) for the same waveform as stereo recording when an oscilloscope is used. (Adjust to the same frequency when a frequency counter is used.)

11.5 BIAS TRAP ADJUSTMENT

1. Connect an oscilloscope to test points TP_{301} (L ch), TP_{302} (R ch) of the power and oscillation ass'y RWR-053 (Fig. 35).
2. Set the BIAS switch to the LH position and place the set into the record state.
3. Adjust L_{303} (L ch) and L_{304} (R ch) for minimum bias leakage waveform (1Vp-p or less) at the oscilloscope.

11.6 RECORDING BIAS ADJUSTMENT

- Connect a voltmeter (millivoltmeter) to the LINE OUTPUT terminals and apply a 1kHz, -10dBv (316mV) signal to the LINE INPUT terminals (Fig. 33).
- Set the MONITOR switch to the SOURCE position.

1. Adjust the LINE input control so that the voltmeter (millivoltmeter) reads -7dBv (450mV).
2. Set the BIAS switch and EQ switch to LH and the MONITOR switch to TAPE.
3. While simultaneously recording and playing back with test tape STD-502, turn the bias adjustment semifixed resistor VR_{303} (L ch), VR_{304} (R ch) clockwise from minimum value to maximum value and adjust to the point at which the playback level drops 0.2dB past the maximum value (Fig. 36).
4. Since the adjustments of item 3 effect each other, repeat adjustment several times.

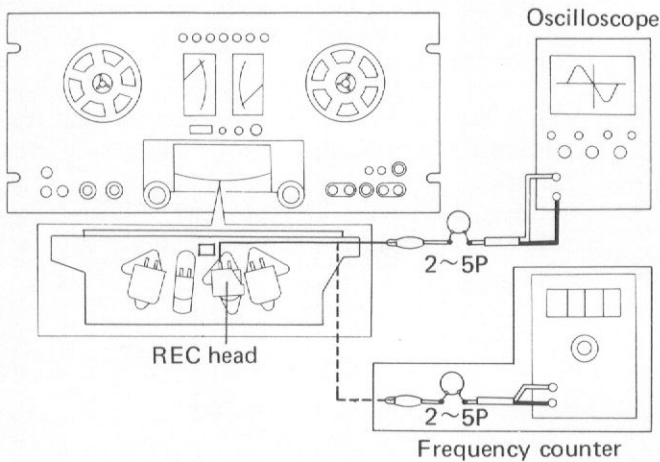

Fig. 34

Power and Oscillation Assembly (RWR-053)

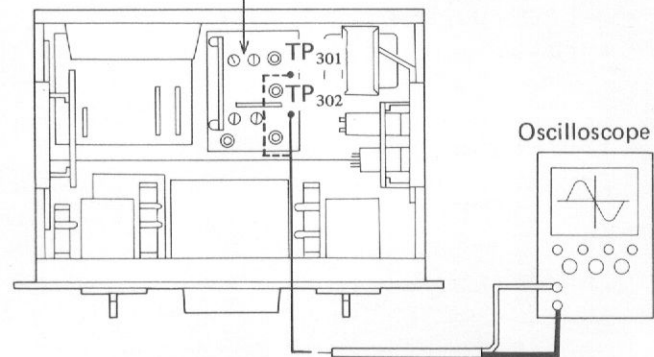

Fig. 35

11.7 RECORD/PLAY FREQUENCY RESPONSE

- Perform this adjustment after "Recording bias adjustment" is complete.
- Connect a voltmeter (millivoltmeter) to the LINE OUTPUT terminals and apply a 1kHz signal to the LINE INPUT terminals (Fig. 33).
- Set the BIAS switch and EQ switch to LH and the MONITOR switch to SOURCE.

1. Adjust the LINE input control for a reading of -7dBv (450mV) at the voltmeter (millivoltmeter).
2. Reduce the input level 20dB more without moving the LINE input control and record/playback a 1kHz and 15kHz signal at test tape STD-502.
3. Confirm that the 15kHz level deviation for 1kHz is $-3\text{dB} \pm 1.5$. When this deviation is -4dB or greater, adjust to -3dB with the bias adjustment semifixed resistors VR₃₀₃ (L ch), VR₃₀₄ (R ch).

Furthermore, perform this adjustment within the range at which the bias does not become an underbias lower than the maximum sensitivity bias value.

11.8 RECORDING LEVEL ADJUSTMENT

- Connect a voltmeter (millivoltmeter) to the LINE OUTPUT terminals (Fig. 33).
- Apply a 1kHz -10dBv (316mV) signal to the LINE INPUT terminal.
- Set the BIAS switch to LH and the EQ switch to LH.

1. Adjust the LINE input control for a reading of -7dBv (450mV) at the voltmeter (millivoltmeter).
2. Adjust semifixed resistor VR₃₀₁ (L ch) and VR₃₀₂ (R ch) so that the voltmeter (millivoltmeter) reads -7dBv (450mV) when the MONITOR switch has been set to TAPE while recording.

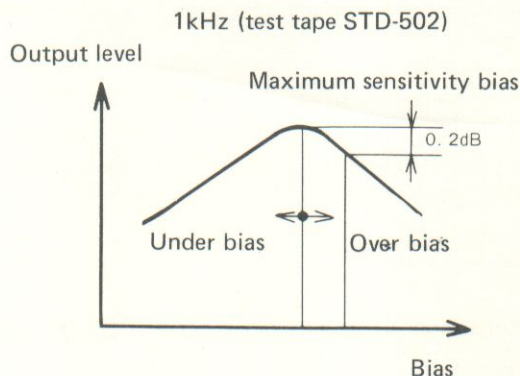

Fig. 36

Playback amplifier assembly (RWF-069)

Power and oscillation assembly (RWR-053)

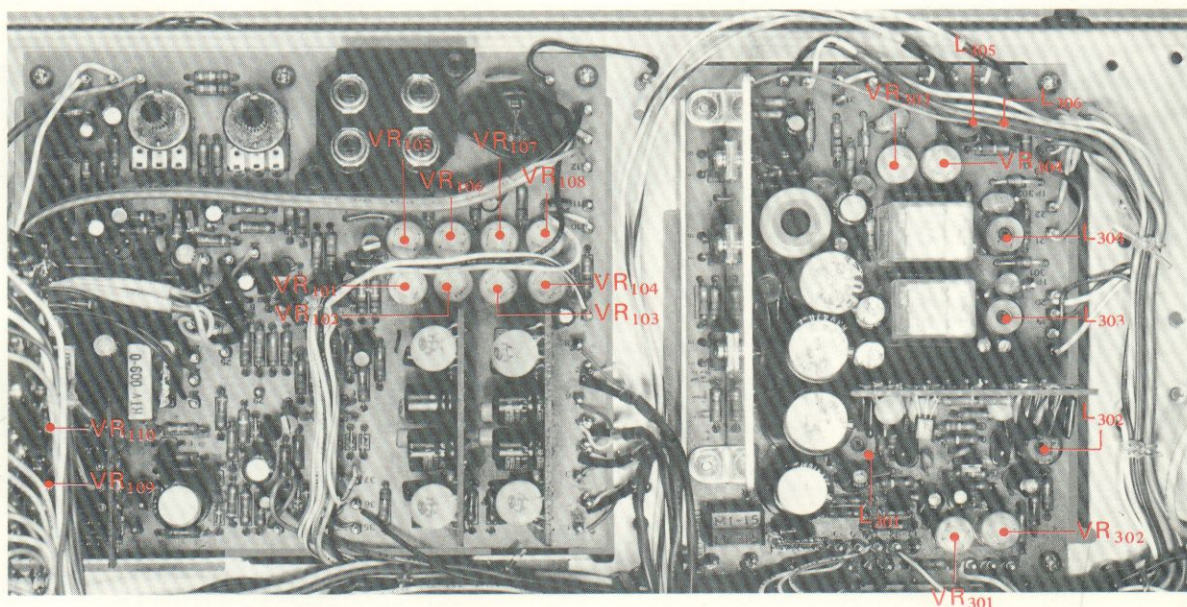





















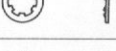
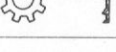
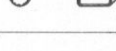
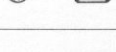
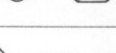

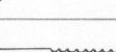

PHOTO 1

12. EXPOLODED VIEWS

Nomenclature of Screws, Washers and Nuts

The following symbols stand for screws, washers and nuts as shown in exploded view.

Symbol	Description	Shape
RT	Brazier head tapping screw	
PT	Pan head tapping screw	
BT	Binding head tapping screw	
CT	Countersunk head tapping screw	
TT	Truss head tapping screw	
OCT	Oval countersunk head tapping screw	
PM	Pan head machine screw	
CM	Countersunk head machine screw	
OCM	Oval countersunk head machine screw	
TM	Truss head machine screw	
BM	Binding head machine screw	
PSA	Pan head screw with spring lock washer	
PSB	Pan head screw with spring lock washer and flat washer	
PSF	Pan head screw with flat washer	

Symbol	Description	Shape
EW	E type washer	
FW	Flat washer	
SW	Spring lock washer	
N	Nut	
WN	Washer faced nut	
ITW	Internal toothed lock washer	
OTW	Outernal toothed lock washer	
SC	Slotted set screw (Cone point)	
SF	Slotted set screw (Flat point)	
HS	Hexagon socket headless set screw	
OCW	Oval countersunk head wood screw	
CW	Countersunk head wood screw	
RW	Round head wood screw	

EXAMPLE

PM · 3x8
 length in mm (l)
 diameter in mm (d)
 Symbol

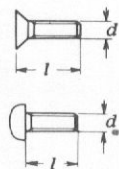

FW · 9φ x 1^t
 thickness in mm (t)
 diameter in mm (d)
 Symbol

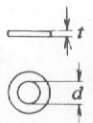

External View

NOTE:
Parts indicated in green type cannot be supplied.

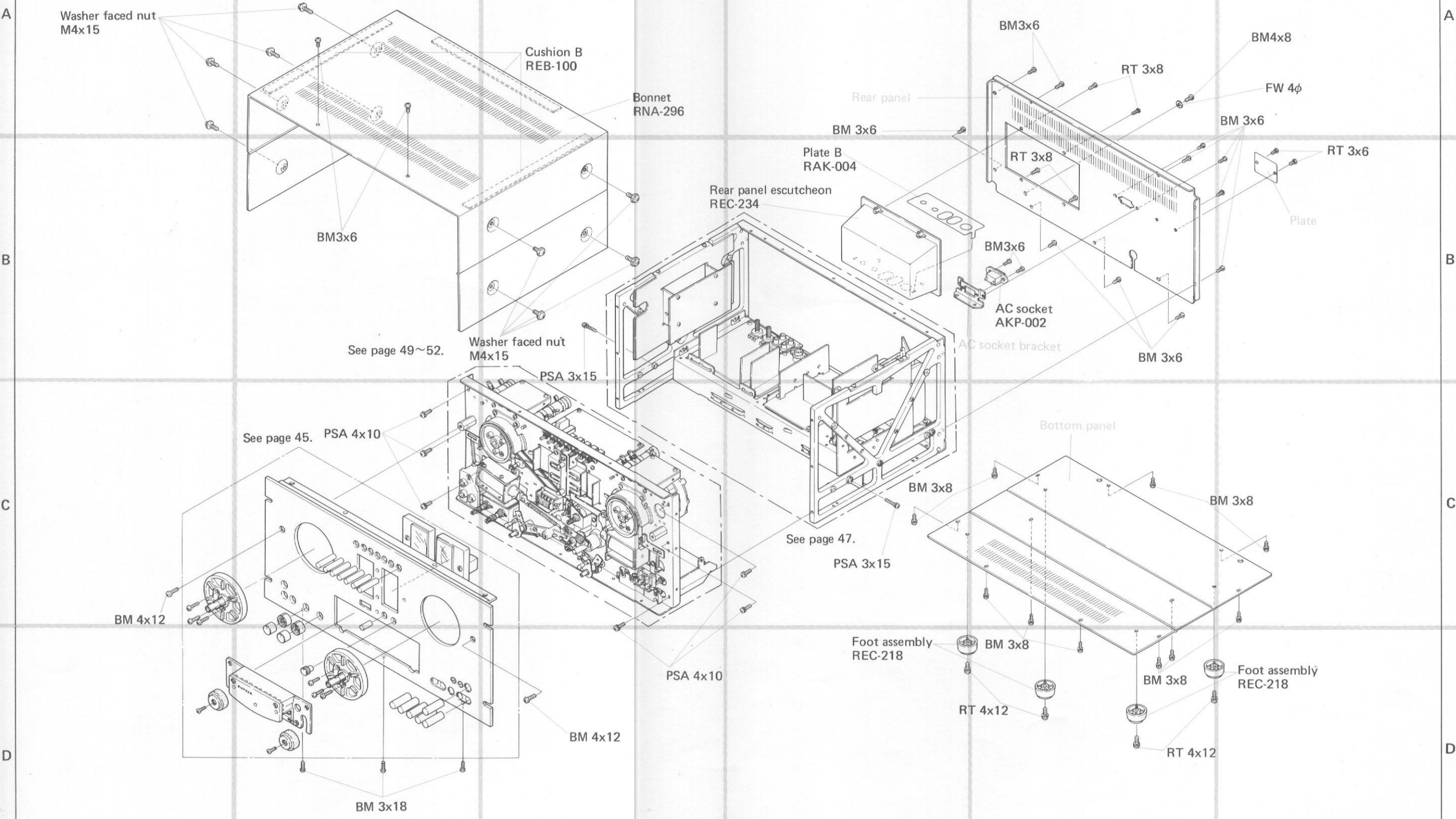

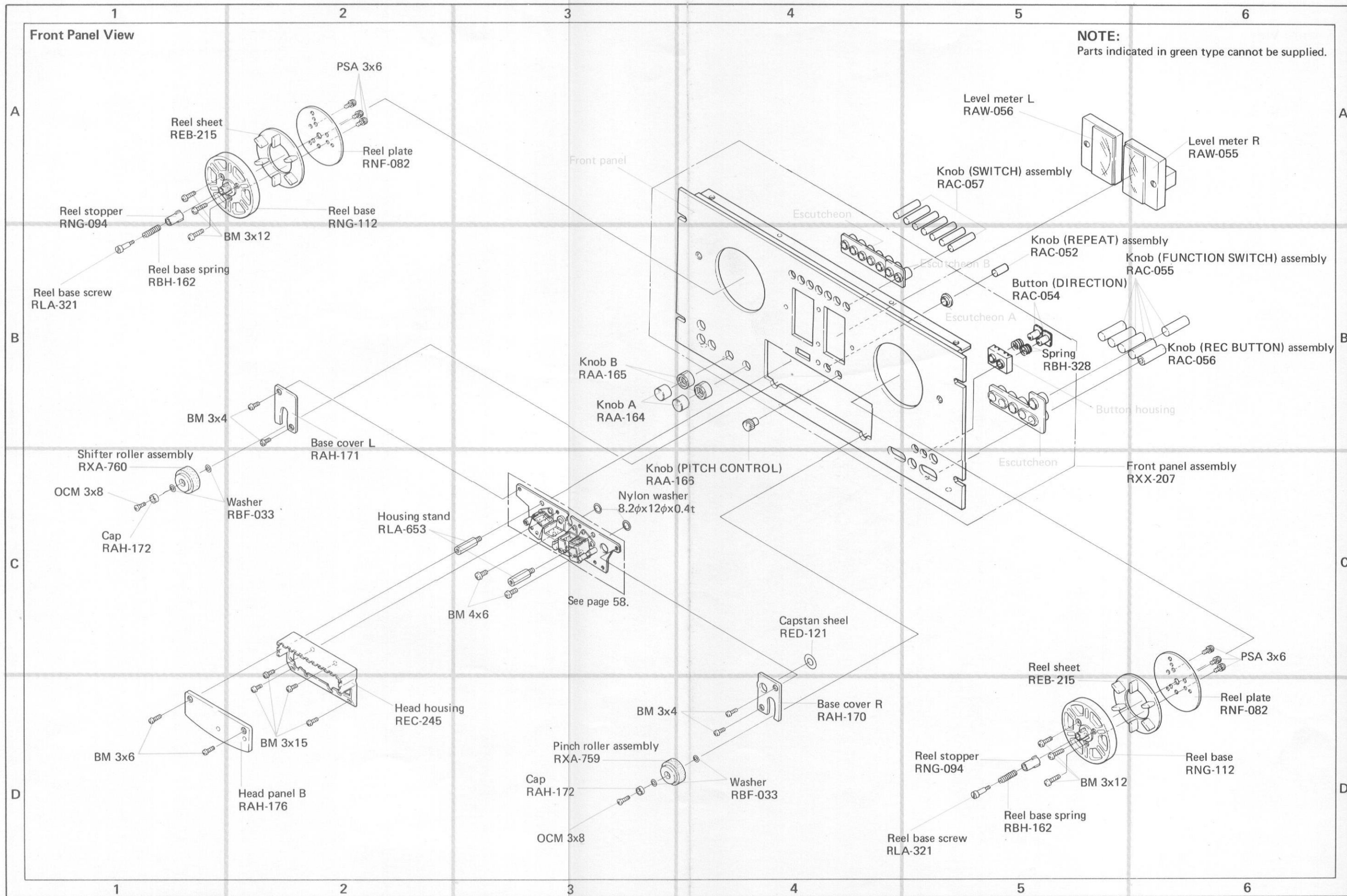

Structure View

NOTE:
Parts indicated in green type cannot be supplied.

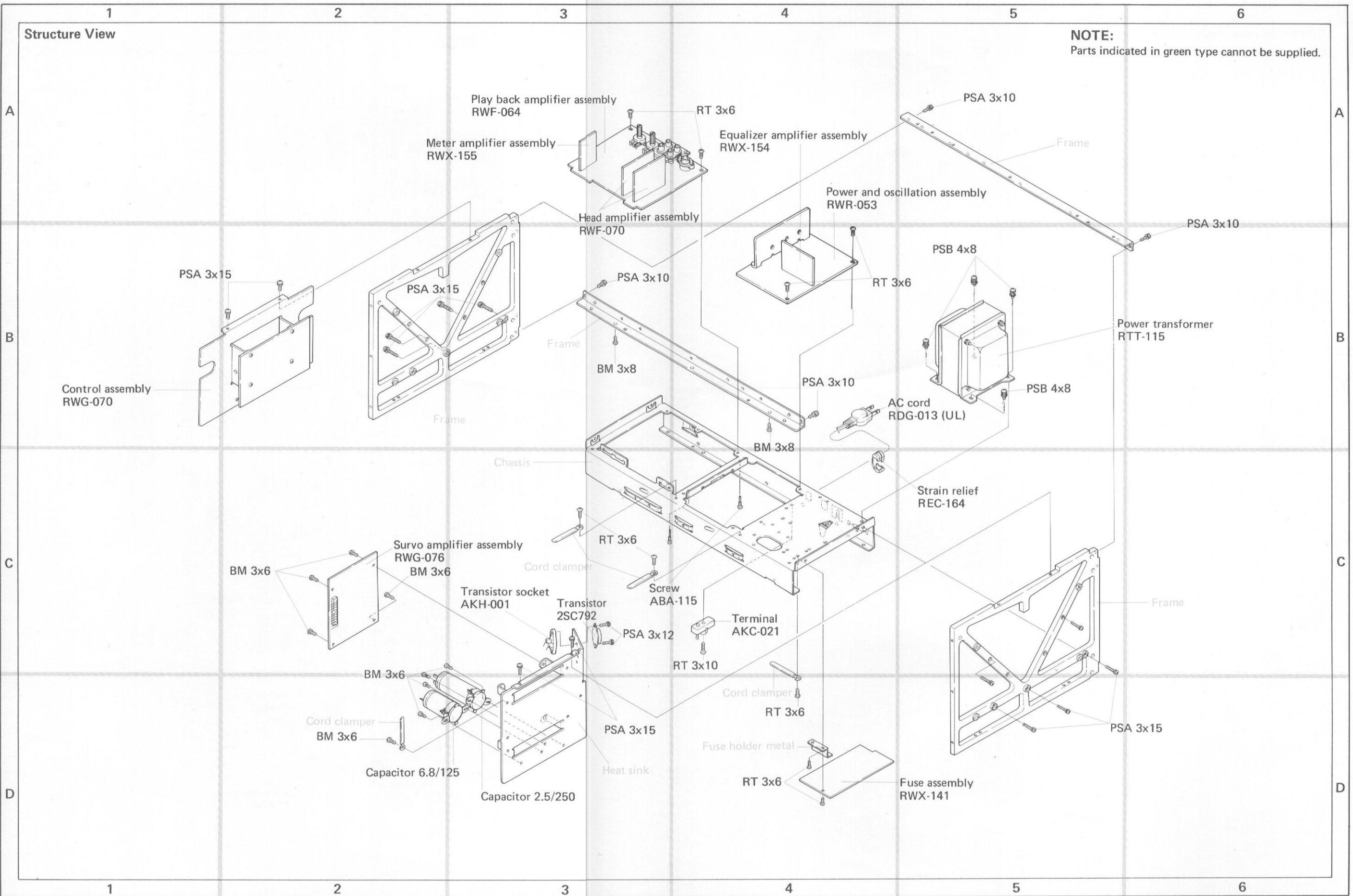

Front side view of mechanism chassis

NOTE:
Parts indicated in green type cannot be supplied.

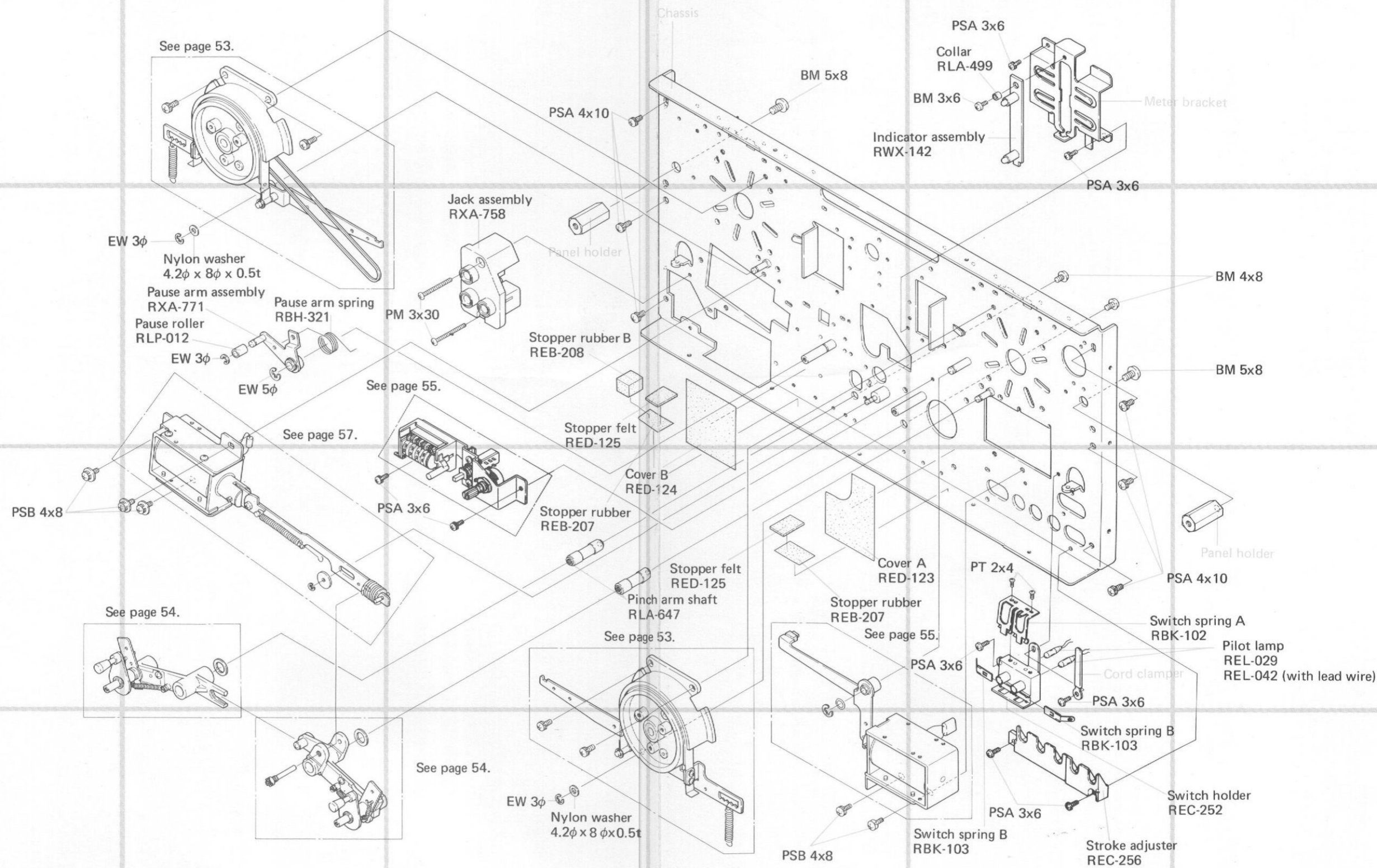

Rear side view of mechanism chassis

NOTE:
Parts indicated in green type cannot be supplied.

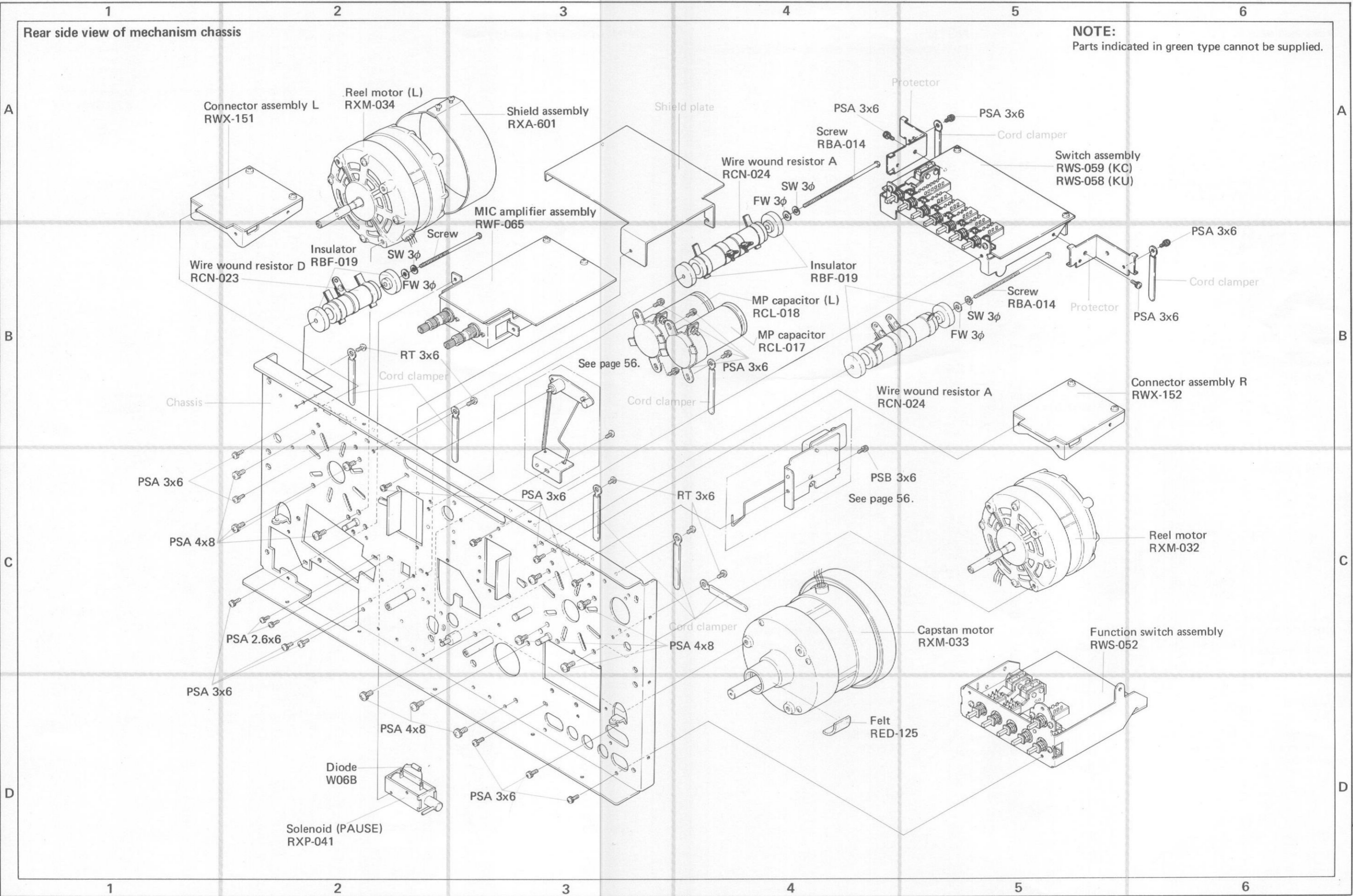

1
Brake assembly R

NOTE:

Parts indicated in green type cannot be supplied.

Brake arm R assembly
RXA-767

BM 4x8

Brake guide
RNK-296

Brake band assembly
RXA-772

Set screw 4x8

Brake felt

Brake band

EW 3φ

Brake spring
RBH-313

Brake drum
RNK-303

PSA 2.6x2

Brake adjustment plate
RNF-074

Brake assembly L

Brake spring
RBH-313

BM 4x8

Brake guide
RNK-296

Brake adjustment plate
RNF-074

Brake felt

Brake arm L assembly
RXA-766

Set screw 4x8

PSA 2.6x6

Brake band

Counter belt
REB-205

Brake drum
RNK-303

EW 3φ

Brake band assembly
RXA-772

1

2

3

Shifter roller arm assembly

Shifter roller arm assembly
RXA-762

Nylon washer
8.2φx12φx0.5t

Tension arm L assembly
RXA-782

Spring hook
RLA-657

Tension holder L
RNF-147

PSA 3x6

EW 4φ

Washer
RBF-033

T spring A
RBH-329

Nylon washer
8.2φx12φx0.5t

Pinch roller arm assembly

Shifter roller
RLP-004

PSA 3x6

Arm pin A
RLA-659

Spring hook
RLA-657

Pinch roller arm assembly
RXA-761

PSA 3x6

Tension arm R assembly
RXA-781

Tension holder R
RNF-146

EW 4φ

Washer
PBF-033

T spring A
RBH-329

1

2

3

A

A

B

B

C

C

D

D

1 Solenoid (BRAKE) assembly

NOTE:

Parts indicated in green type cannot be supplied.

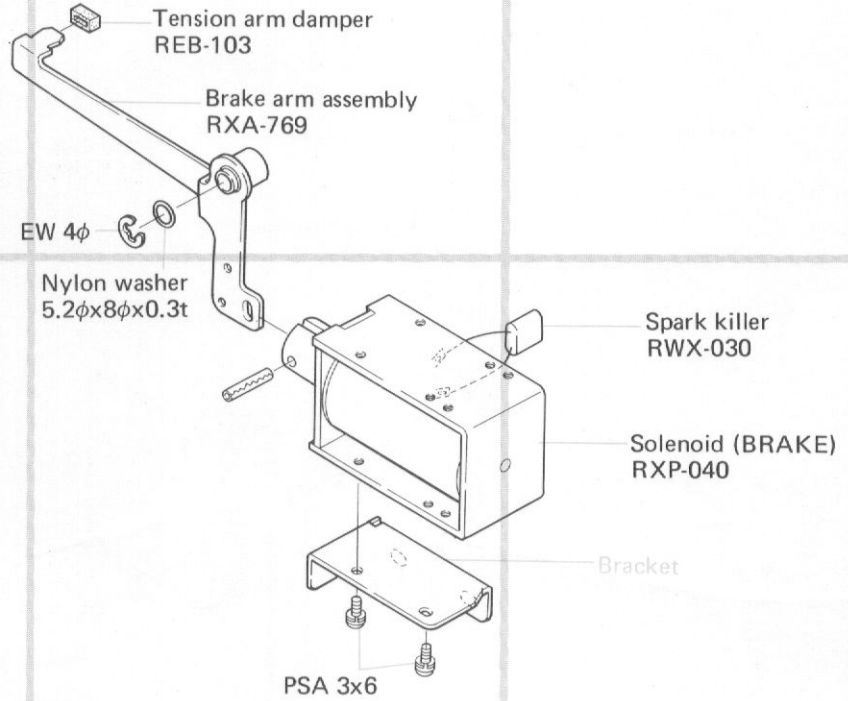

C Tape counter assembly

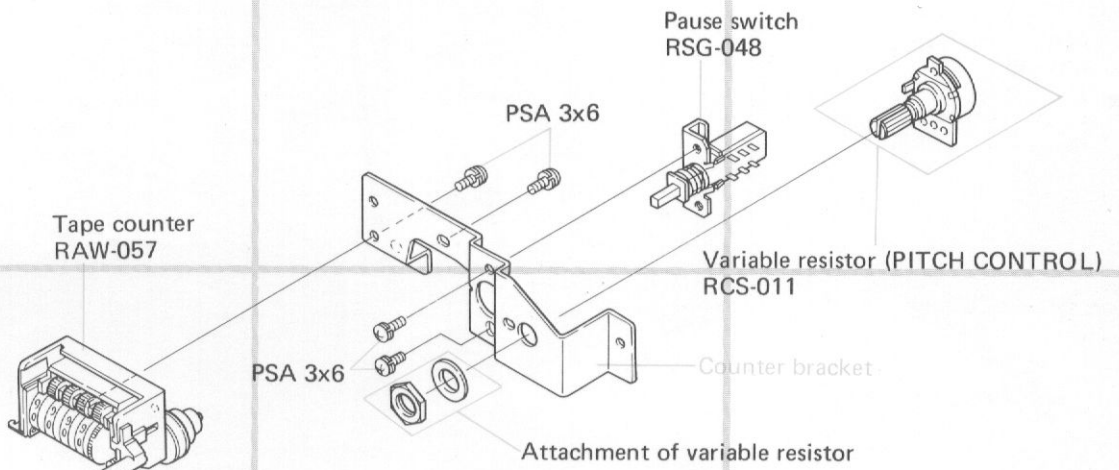

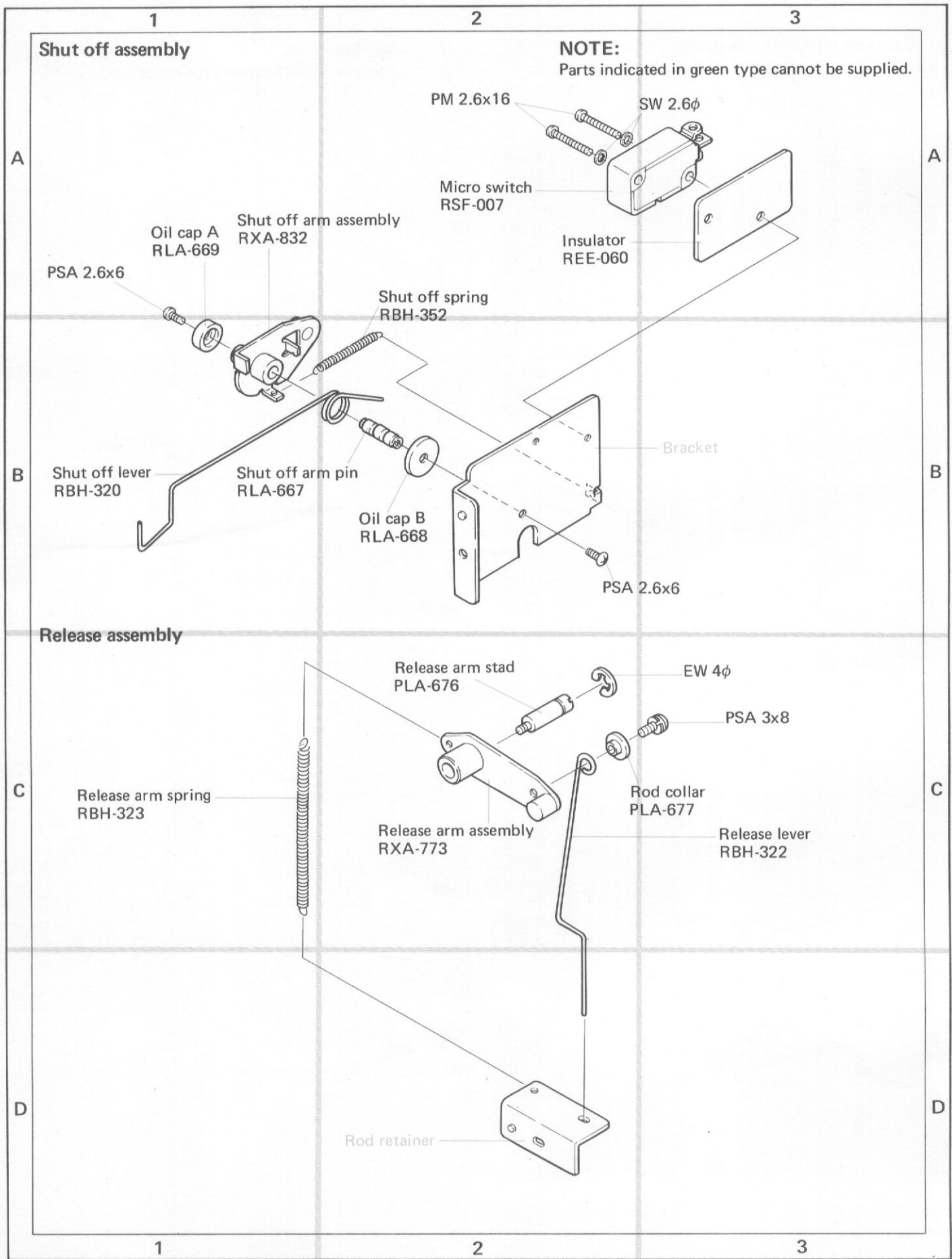

1

2

3

Solenoid (PINCH) assembly

NOTE:

Parts indicated in green type cannot be supplied.

A

A

B

B

C

C

D

D

Solenoid (PINCH)
RXP-038

Diode
W06B

PSA 3x6

Bracket

PSA 3x6

PSB 3x6

Pause adjuster
RNF-104

Solenoid bar assembly
RXA-774

Spring retainer A
RNK-297

T Spring B
RBH-326

Spring C
RBH-325

Spring retainer B
RLA-652

FW
12φx3.2φx1t

EW 2φ

Pin
RLA-658

1

2

3

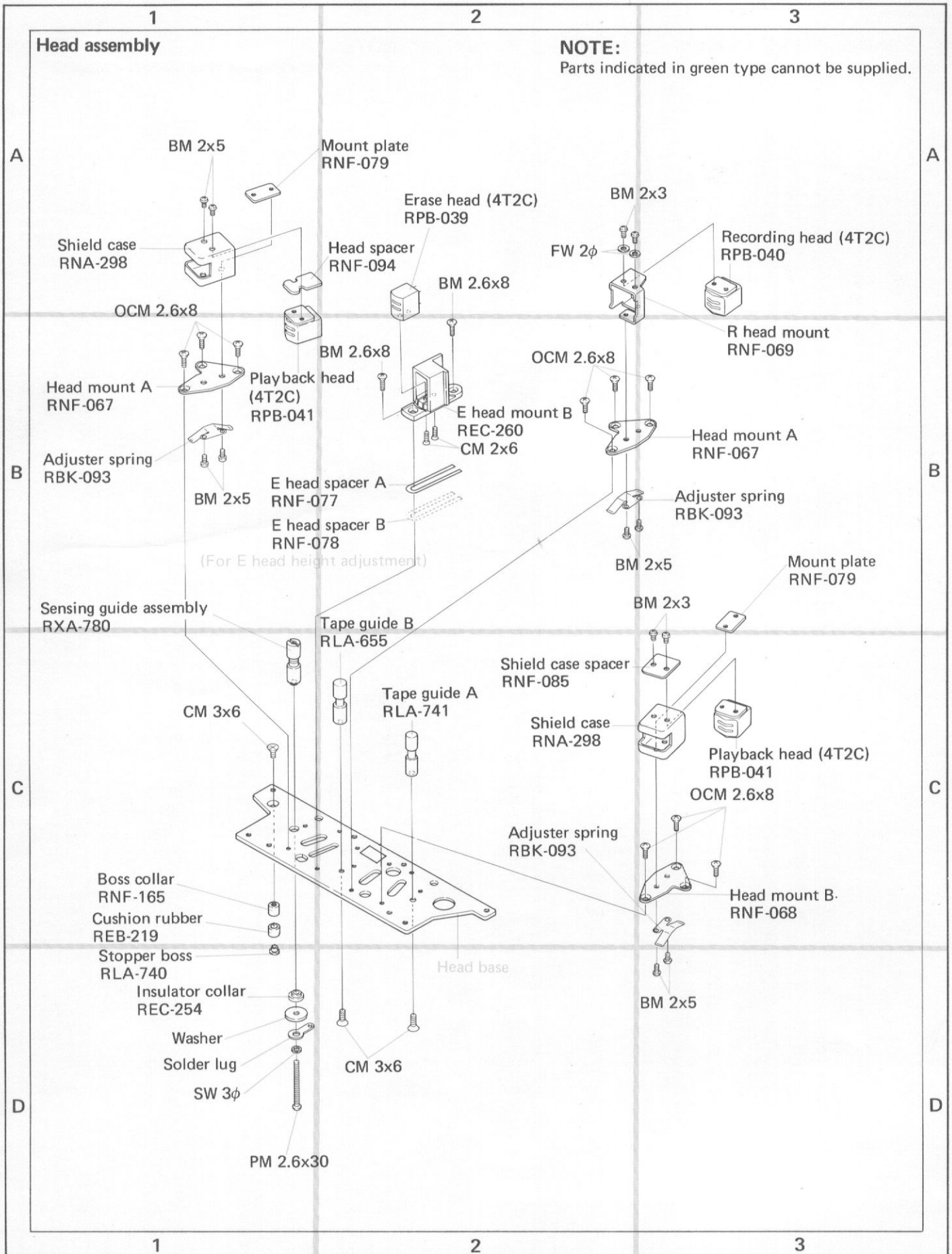

13. SCHEMATIC DIAGRAMS, P.C. BOARD PATTERNS AND PARTS LIST

13.1 MISCELLANEOUS PARTS LIST

NOTE:

- Capacitors: in μF unless otherwise noted $p:pF$.
- Resistors: in Ω , $\frac{1}{4}W$ unless otherwise noted $k:k\Omega$, $M:M\Omega$

CAPACITORS

Symbol	Description	Part No.
C1	MP capacitor	RCL-017
C2	MP capacitor (L)	RCL-018

RESISTORS

Symbol	Description	Part No.
R1	Wire wound resistor D 2k 20W	RCN-023
R2	Wire wound resistor A 350 25W	RCN-024
R3	Wire wound resistor A 350 25W	RCN-024
R4	Carbon film 1.5k	RD $\frac{1}{4}$ PS 152J
R5	Carbon film 1.5k	RD $\frac{1}{4}$ PS 152J
VR4	Variable resistor (PITCH CONTROL) 10k-B	RCS-011

SEMICONDUCTORS

Symbol	Description	Part No.
D1	Diode W06B	
D2	Diode W06B	

TRANSFORMER

Symbol	Description	Part No.
	Power transformer	RTT-115

OTHERS

Symbol	Description	Part No.
VU1	Level meter L	RAW-056
VU2	Level meter R	RAW-055
CR1	Spark killer	RWX-030
CR2	Spark killer	RWX-030
S15	PAUSE switch	RSG-048
S16	Micro switch	RSF-007
	Reel motor	RXM-032
	Capstan motor	RXM-035
	Reel motor L	RXM-034

Symbol	Description	Part No.
	Solenoid (PINCH)	RXP-038
	Solenoid (BRAKE)	RXP-040
	Solenoid (PAUSE)	RXP-041
	Erase head (4T2C)	RPB-039
	Recording head (4T2C)	RPB-040
	Playback head (4T2C)	RPB-041
	Power and oscillation assembly	RWS-053
	Playback amplifier assembly	RWF-069
	Fuse assembly	RWX-141
	Mic amplifier assembly	RWF-065
	Switch assembly (KU)	RWS-058
	Switch assembly (KC)	RWS-059
	Function switch assembly	RWS-052
	Control assembly	RWG-070
	Connector assembly L	RWX-151
	Connector assembly R	RWX-152
	Power cord (KU)	RDG-013

List of changed parts information will be furnished whenever necessary and you are requested to amend parts number in this parts list.

List of Changed Parts for Factory Modification

Symbol	Description	Part No.

13.2 EXTERNAL APPEARANCE OF TRANSISTORS, ICS AND CIRCUIT DIAGRAMS OF IC

External view

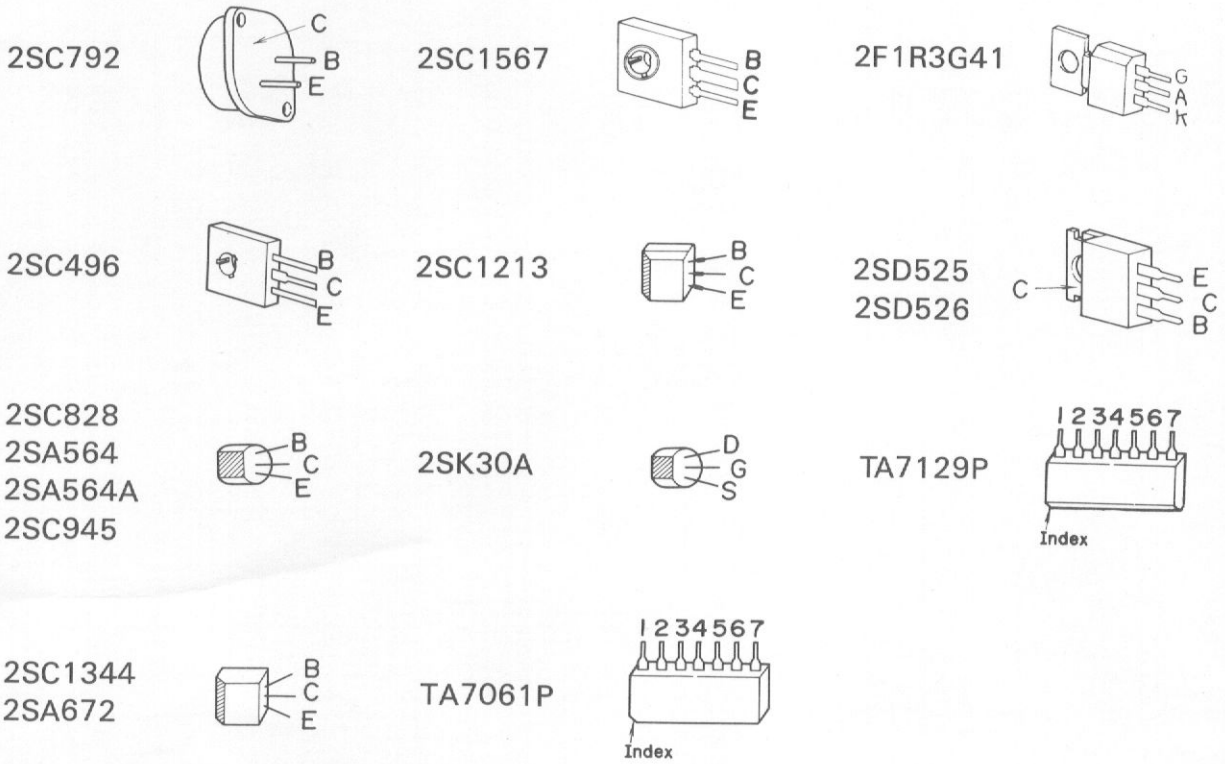

Circuit diagram

TA7061AP

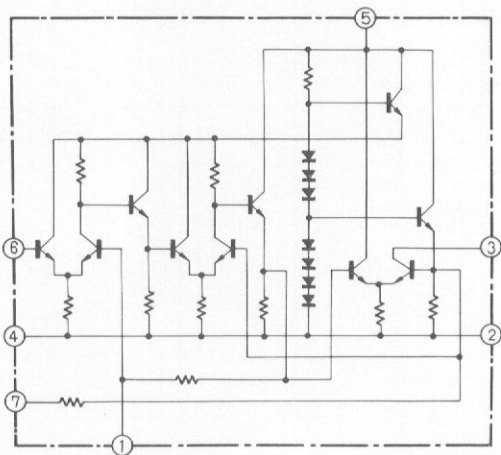

TA7129P

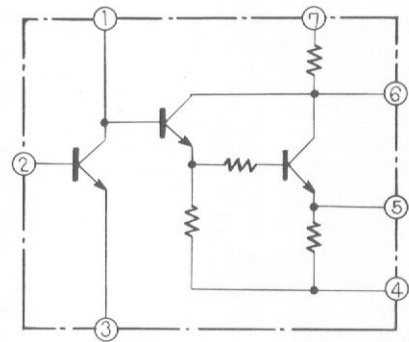

13.3 CONNECTION DIAGRAM

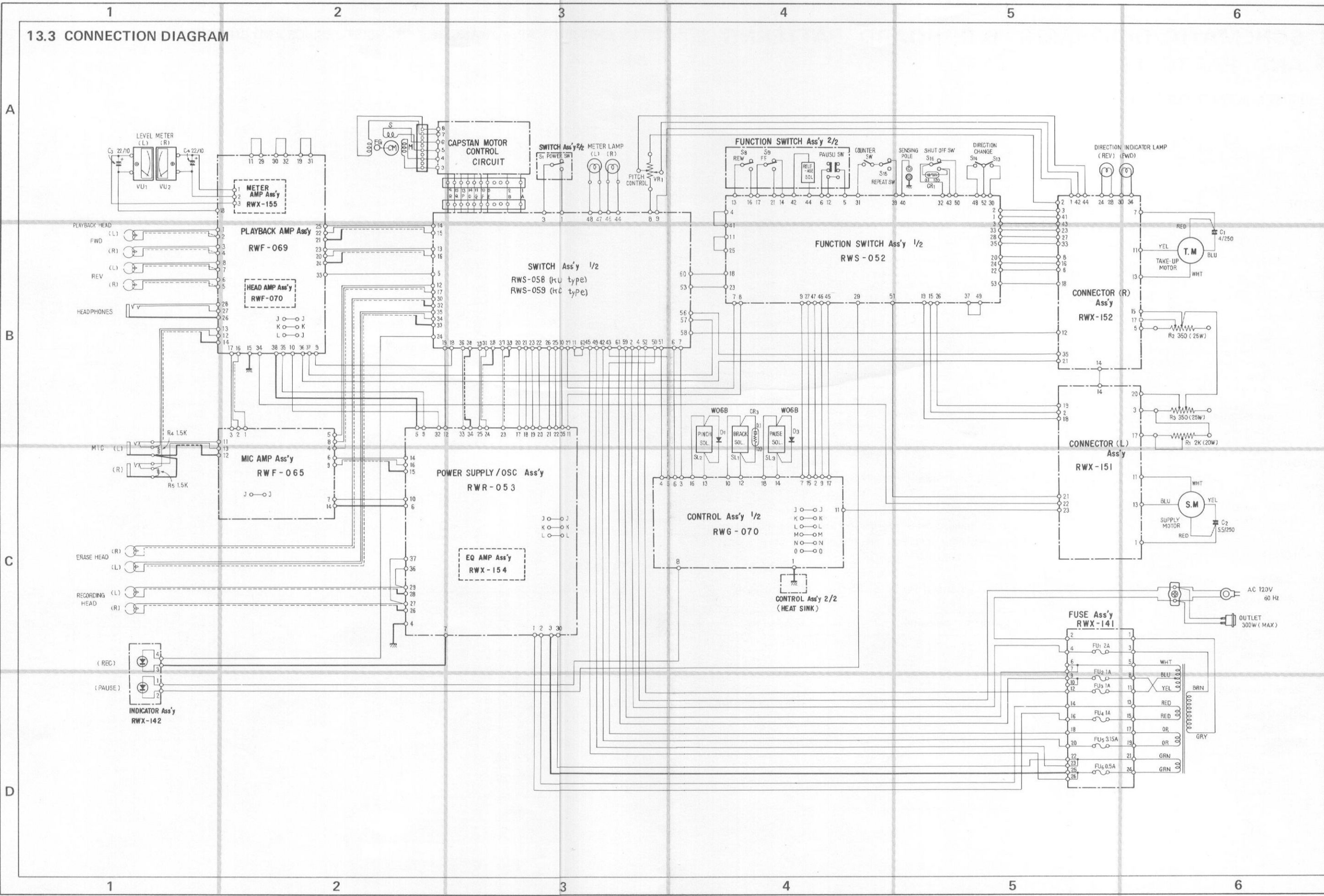

13.4 SCHEMATIC DIAGRAM

NOTE:

The indicated semiconductors are representative ones only. Other alternative semiconductors may be used and are listed in the parts lists.

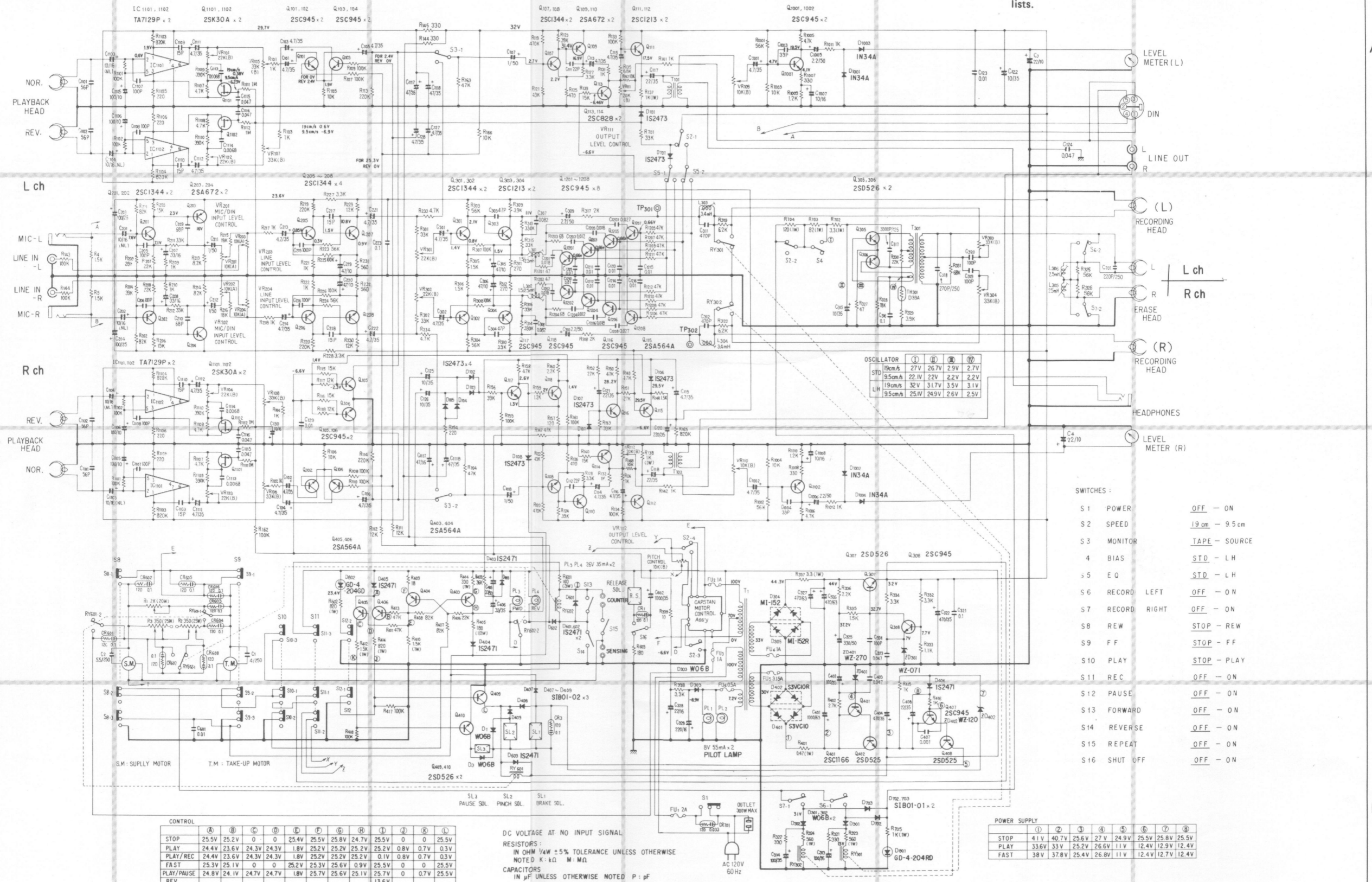

CONTROL

	(A)	(B)	(C)	(D)	(E)	(F)	(G)	(H)	(I)	(J)	(K)	(L)
STOP	25.5V	25.2V	0	0	25.4V	25.5V	25.8V	24.7V	25.5V	0	0	25.5V
PLAY	24.4V	23.6V	24.3V	24.3V	1.8V	25.2V	25.2V	25.2V	0.8V	0.7V	0.3V	0.3V
PLAY/REC	24.4V	23.6V	24.3V	24.3V	1.8V	25.2V	25.2V	25.2V	0.1V	0.8V	0.7V	0.3V
FAST	25.3V	25.1V	0	0	25.2V	25.3V	25.6V	0.9V	25.5V	0	0	25.5V
PLAY/PAUSE	24.8V	24.1V	24.7V	24.7V	1.8V	25.7V	25.6V	25.7V	0	0.7V	25.5V	
REV												13.6V

DC VOLTAGE AT NO INPUT SIGNAL
RESISTORS: IN OHM 1/4W ±5% TOLERANCE UNLESS OTHERWISE NOTED K: K Ω M: M Ω
CAPACITORS: IN μF UNLESS OTHERWISE NOTED P: pF

POWER SUPPLY

	(1)	(2)	(3)	(4)	(5)	(6)	(7)	(8)
STOP	4.1V	40.7V	25.6V	27V	24.9V	25.5V	25.8V	25.5V
PLAY	33.6V	33V	25.2V	26.6V	11V	12.4V	12.9V	12.4V
FAST	38V	37.8V	25.4V	26.8V	11V	12.4V	12.7V	12.4V

- SWITCHES:
- S1 POWER OFF - ON
 - S2 SPEED 19 cm - 9.5 cm
 - S3 MONITOR TAPE - SOURCE
 - 4 BIAS STD - LH
 - 5 EQ STD - LH
 - S6 RECORD LEFT OFF - ON
 - S7 RECORD RIGHT OFF - ON
 - S8 REW STOP - REW
 - S9 FF STOP - FF
 - S10 PLAY STOP - PLAY
 - S11 REC OFF - ON
 - S12 PAUSE OFF - ON
 - S13 FORWARD OFF - ON
 - S14 REVERSE OFF - ON
 - S15 REPEAT OFF - ON
 - S16 SHUT OFF OFF - ON

13.5 PLAYBACK AMPLIFIER ASSEMBLY (RWF-069)

VR₁₁₁, VR₁₁₂
OUTPUT LEVEL CONTROL

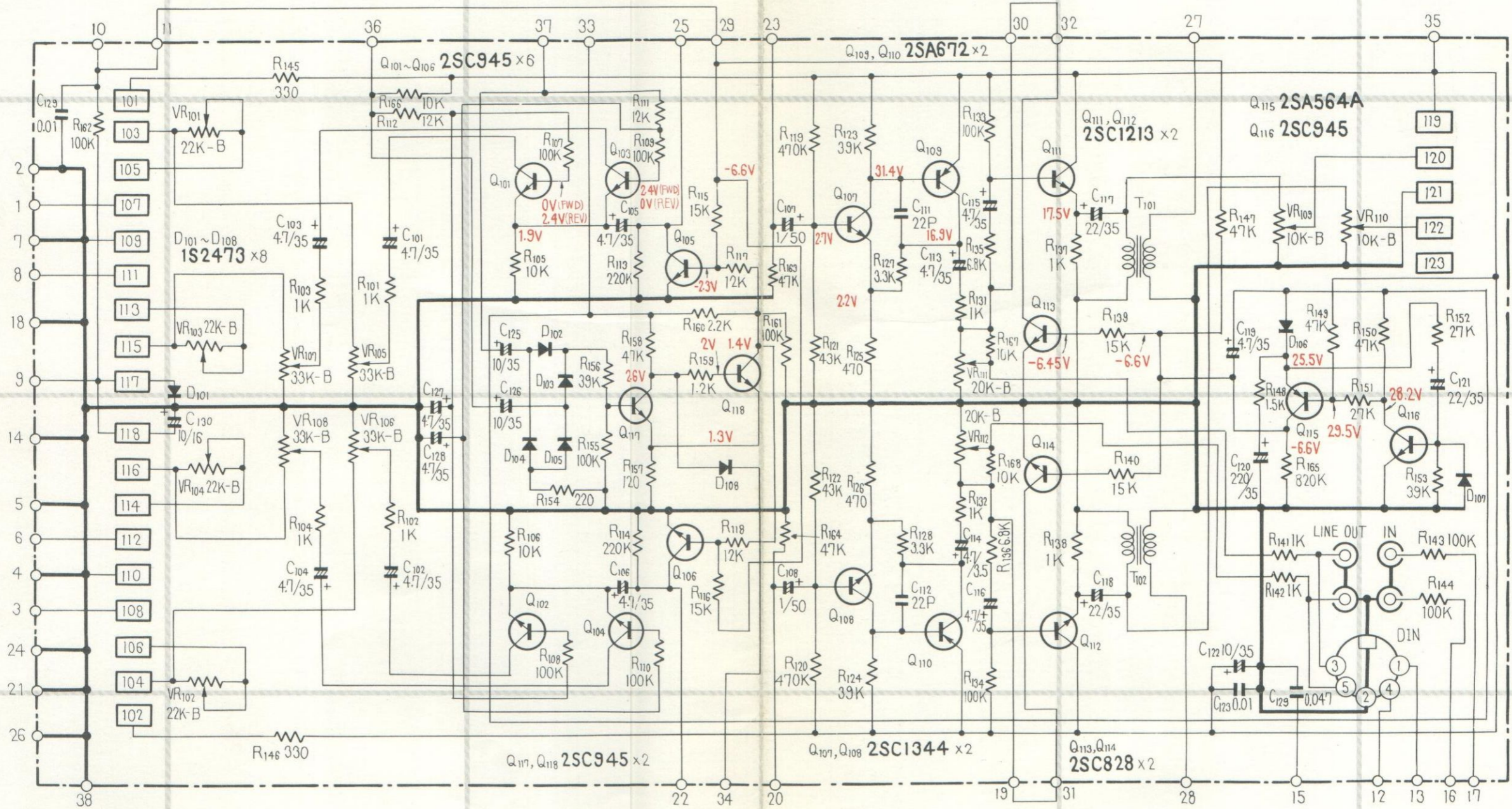

Parts List of Playback Amplifier Assembly (RWF-069)

TRANSFORMERS

Symbol	Description	Part No.	Symbol	Description	Part No.
T101	Matching transformer	RTV-009	R101	Carbon film 1k	RD $\frac{1}{4}$ PS 102J
T102	Matching transformer	RTV-009	R102	Carbon film 1k	RD $\frac{1}{4}$ PS 102J

CAPACITORS

Symbol	Description	Part No.	Symbol	Description	Part No.
C101	Electrolytic 4.7 35V	CEA 4R7P 35	R106	Carbon film 10k	RD $\frac{1}{4}$ PS 103J
C102	Electrolytic 4.7 35V	CEA 4R7P 35	R107	Carbon film 100k	RD $\frac{1}{4}$ PS 104J
C103	Electrolytic 4.7 35V	CEA 4R7P 35	R108	Carbon film 100k	RD $\frac{1}{4}$ PS 104J
C104	Electrolytic 4.7 35V	CEA 4R7P 35	R109	Carbon film 100k	RD $\frac{1}{4}$ PS 104J
C105	Electrolytic 4.7 35V	CEA 4R7P 35	R110	Carbon film 100k	RD $\frac{1}{4}$ PS 104J
C106	Electrolytic 4.7 35V	CEA 4R7P 35	R111	Carbon film 12k	RD $\frac{1}{4}$ PS 123J
C107	Electrolytic 1 50V	CEA 010P 50	R112	Carbon film 12k	RD $\frac{1}{4}$ PS 123J
C108	Electrolytic 1 50V	CEA 010P 50	R113	Carbon film 220k	RD $\frac{1}{4}$ PS 224J
C111	Ceramic 22p 50V	CCDSL 220K 50	R114	Carbon film 220k	RD $\frac{1}{4}$ PS 224J
C112	Ceramic 22p 50V	CCDSL 220K 50	R115	Carbon film 15k	RD $\frac{1}{4}$ PS 153J
C113	Electrolytic 4.7 35V	CEA 4R7P 35	R116	Carbon film 15k	RD $\frac{1}{4}$ PS 153J
C114	Electrolytic 4.7 35V	CEA 4R7P 35	R117	Carbon film 12k	RD $\frac{1}{4}$ PS 123J
C115	Electrolytic 4.7 35V	CEA 4R7P 35	R118	Carbon film 12k	RD $\frac{1}{4}$ PS 123J
C116	Electrolytic 4.7 35V	CEA 4R7P 35	R119	Carbon film 470k	RD $\frac{1}{4}$ PS 474J
C117	Electrolytic 22 35V	CEA 220P 35	R120	Carbon film 470k	RD $\frac{1}{4}$ PS 474J
C118	Electrolytic 22 35V	CEA 220P 35	R121	Carbon film 43k	RD $\frac{1}{4}$ PS 433J
C119	Electrolytic 4.7 35V	CEA 4R7P 35	R122	Carbon film 43k	RD $\frac{1}{4}$ PS 433J
C120	Electrolytic 220 35V	CEA 221P 35	R123	Carbon film 39k	RD $\frac{1}{4}$ PS 393J
C121	Electrolytic 22 35V	CEA 220P 35	R124	Carbon film 39k	RD $\frac{1}{4}$ PS 393J
C122	Electrolytic 10 35V	CEA 100P 35	R125	Carbon film 470	RD $\frac{1}{4}$ PS 471J
C123	Ceramic 0.01 50V	CKDYF 103Z 50	R126	Carbon film 470	RD $\frac{1}{4}$ PS 471J
C124	Ceramic 0.047 50V	CKDYF 473Z 50	R127	Carbon film 3.3k	RD $\frac{1}{4}$ PS 332J
C125	Electrolytic 10 35V	CEA 100P 35	R128	Carbon film 3.3k	RD $\frac{1}{4}$ PS 332J
C126	Electrolytic 10 35V	CEA 100P 35	R131	Carbon film 1k	RD $\frac{1}{4}$ PS 102J
C127	Electrolytic 4.7 35V	CEA 4R7P 35	R132	Carbon film 1k	RD $\frac{1}{4}$ PS 102J
C128	Electrolytic 4.7 35V	CEA 4R7P 35	R133	Carbon film 100k	RD $\frac{1}{4}$ PS 104J
C129	Ceramic 0.01 50V	CKDYF 103Z 50	R134	Carbon film 100k	RD $\frac{1}{4}$ PS 104J
C130	Electrolytic 10 16V	CEA 100P 16	R135	Carbon film 6.8k	RD $\frac{1}{4}$ PS 682J
			R136	Carbon film 6.8k	RD $\frac{1}{4}$ PS 682J
			R137	Metal oxide 1k	1W RS1P 102J
			R138	Metal oxide 1k	1W RS1P 102J
			R139	Carbon film 15k	RD $\frac{1}{4}$ PS 153J
			R140	Carbon film 15k	RD $\frac{1}{4}$ PS 153J
			R141	Carbon film 1k	RD $\frac{1}{4}$ PS 102J
			R142	Carbon film 1k	RD $\frac{1}{4}$ PS 102J
			R143	Carbon film 100k	RD $\frac{1}{4}$ PS 104J
			R144	Carbon film 100k	RD $\frac{1}{4}$ PS 104J
			R145	Carbon film 330	RD $\frac{1}{4}$ PS 331J
			R146	Carbon film 330	RD $\frac{1}{4}$ PS 331J
			R147	Carbon film 47k	RD $\frac{1}{4}$ PS 473J
			R148	Carbon film 1.5k	RD $\frac{1}{4}$ PS 152J
			R149	Carbon film 47k	RD $\frac{1}{4}$ PS 473J
			R150	Carbon film 47k	RD $\frac{1}{4}$ PS 473J
			R151	Carbon film 27k	RD $\frac{1}{4}$ PS 273J
			R152	Carbon film 27k	RD $\frac{1}{4}$ PS 273J

RESISTORS

Symbol	Description	Part No.	Symbol	Description	Part No.
VR101	Semi-fixed 22k-B	C92-857	R138	Metal oxide 1k	1W RS1P 102J
VR102	Semi-fixed 22k-B	C92-857	R139	Carbon film 15k	RD $\frac{1}{4}$ PS 153J
VR103	Semi-fixed 22k-B	C92-857	R140	Carbon film 15k	RD $\frac{1}{4}$ PS 153J
VR104	Semi-fixed 22k-B	C92-857	R141	Carbon film 1k	RD $\frac{1}{4}$ PS 102J
VR105	Semi-fixed 33k-B	C81-426	R142	Carbon film 1k	RD $\frac{1}{4}$ PS 102J
VR106	Semi-fixed 33k-B	C81-426	R143	Carbon film 100k	RD $\frac{1}{4}$ PS 104J
VR107	Semi-fixed 33k-B	C81-426	R144	Carbon film 100k	RD $\frac{1}{4}$ PS 104J
VR108	Semi-fixed 33k-B	C81-426	R145	Carbon film 330	RD $\frac{1}{4}$ PS 331J
VR109	Semi-fixed 10k-B	C92-049	R146	Carbon film 330	RD $\frac{1}{4}$ PS 331J
VR110	Semi-fixed 10k-B	C92-049	R147	Carbon film 47k	RD $\frac{1}{4}$ PS 473J
VR111	Variable resistor 20k-B	RCS-013	R148	Carbon film 1.5k	RD $\frac{1}{4}$ PS 152J
VR112	Variable resistor 20k-B	RCS-013	R149	Carbon film 47k	RD $\frac{1}{4}$ PS 473J
			R150	Carbon film 47k	RD $\frac{1}{4}$ PS 473J
			R151	Carbon film 27k	RD $\frac{1}{4}$ PS 273J
			R152	Carbon film 27k	RD $\frac{1}{4}$ PS 273J

OTHERS

<u>Symbol</u>	<u>Description</u>	<u>Part No.</u>	<u>Symbol</u>	<u>Description</u>	<u>Part No.</u>
R153	Carbon film	39k	RD¼PS 393J	Head amplifier assembly	RWF-070
R154	Carbon film	220	RD¼PS 221J	Meter amplifier assembly	RWX-155
R155	Carbon film	100k	RD¼PS 104J	DIN connector socket (5P)	RKP-030
R156	Carbon film	39k	RD¼PS 393J	Terminal (INPUT, OUTPUT)	RKB-011
R157	Carbon film	120	RD¼PS 121J		
R158	Carbon film	47k	RD¼PS 473J		
R159	Carbon film	1.2k	RD¼PS 122J		
R160	Carbon film	2.2k	RD¼PS 222J		
R161	Carbon film	100k	RD¼PS 104J		
R162	Carbon film	100k	RD¼PS 104J		
R163	Carbon film	47k	RD¼PS 473J		
R164	Carbon film	47k	RD¼PS 473J		
R165	Carbon film	820k	RD¼PS 824J		
R166	Carbon film	10k	RD¼PS 103J		
R167	Carbon film	10k	RD¼PS 103J		
R168	Carbon film	10k	RD¼PS 103J		

SEMICONDUCTORS

<u>Symbol</u>	<u>Description</u>	<u>Part No.</u>
Q101	Transistor	2SC945-P or Q
Q102	Transistor	2SC945-P or Q
Q103	Transistor	2SC945-P or Q
Q104	Transistor	2SC945-P or Q
Q105	Transistor	2SC945-P or Q
Q106	Transistor	2SC945-P or Q
Q107	Transistor	2SC1344-D or E
Q108	Transistor	2SC1344-D or E
Q109	Transistor	2SA672-B or C
Q110	Transistor	2SA672-B or C
Q111	Transistor	2SC1213-B or C
Q112	Transistor	2SC1213-B or C
Q113	Transistor	2SC828-R or S
Q114	Transistor	2SC828-R or S
Q115	Transistor	2SA564A-R or S
Q116	Transistor	2SC945-P or Q
Q117	Transistor	2SC945-P or Q
Q118	Transistor	2SC945-P or Q
D101	Diode	1S2473
D102	Diode	1S2473
D103	Diode	1S2473
D104	Diode	1S2473
D105	Diode	1S2473
D106	Diode	1S2473
D107	Diode	1S2473
D108	Diode	1S2473

List of Changed Parts for Factory Modification

<u>Symbol</u>	<u>Description</u>	<u>Part No.</u>

1 2 3 4 5 6

A

A

B

B

C

C

D

D

RWX-151, No.22
 RWS-058, No.5
 RWR-053, No.9
 RWX-152, No.21
 RWS-058, No.57

Foil side

METER AMP Ass'y
RWX-155

HEAD AMP
Assy RWF-070

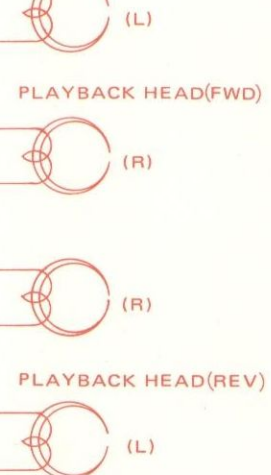
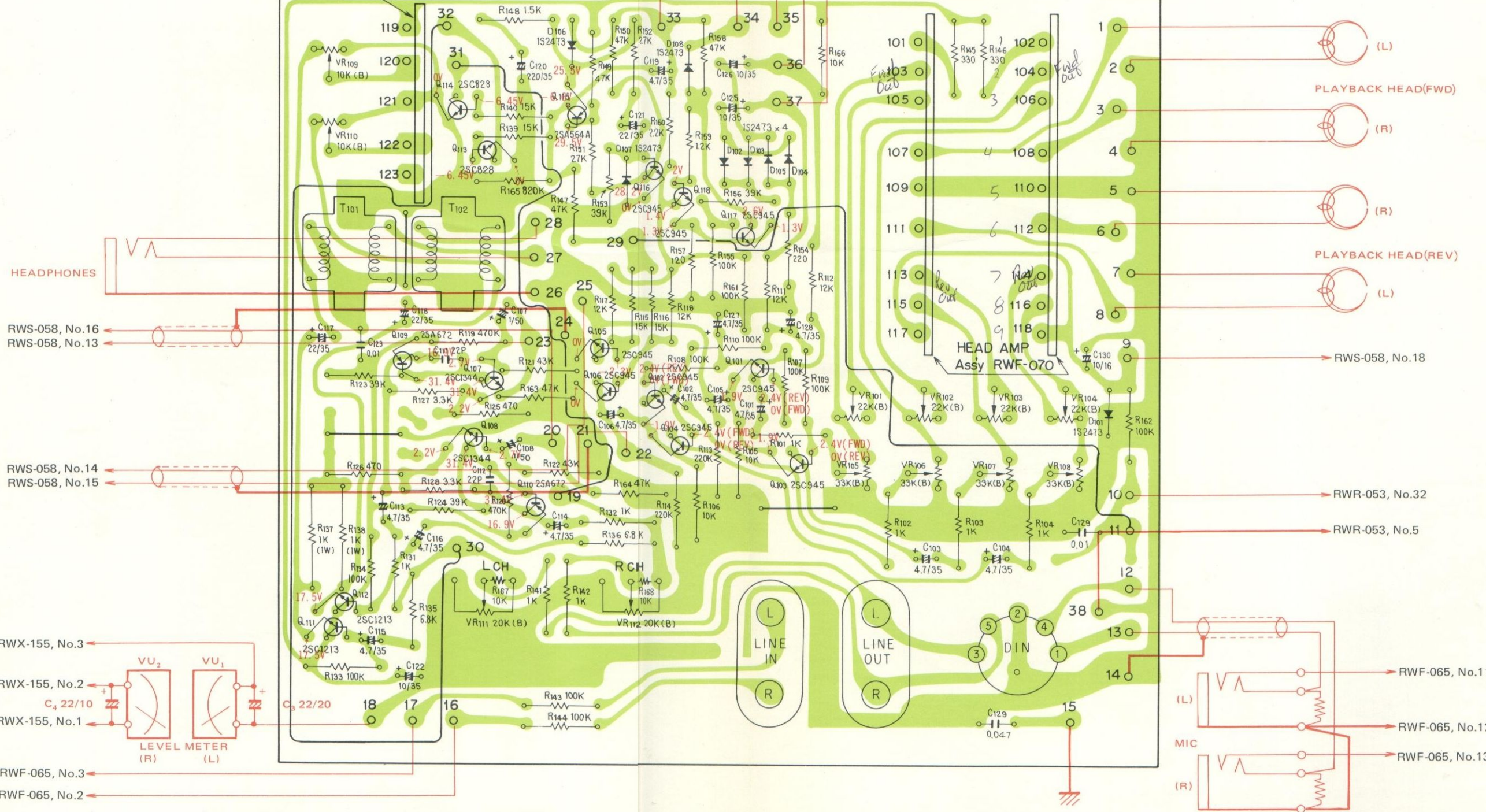

RWS-058, No.16
 RWS-058, No.13

RWS-058, No.14
 RWS-058, No.15

RWS-058, No.18

RWR-053, No.32

RWR-053, No.5

RWX-155, No.3

RWX-155, No.2

RWX-155, No.1

RWF-065, No.3

RWF-065, No.2

RWF-065, No.11

RWF-065, No.12

RWF-065, No.13

1 2 3 4 5 6

13.6 METER AMPLIFIER ASSEMBLY (RWX-155)

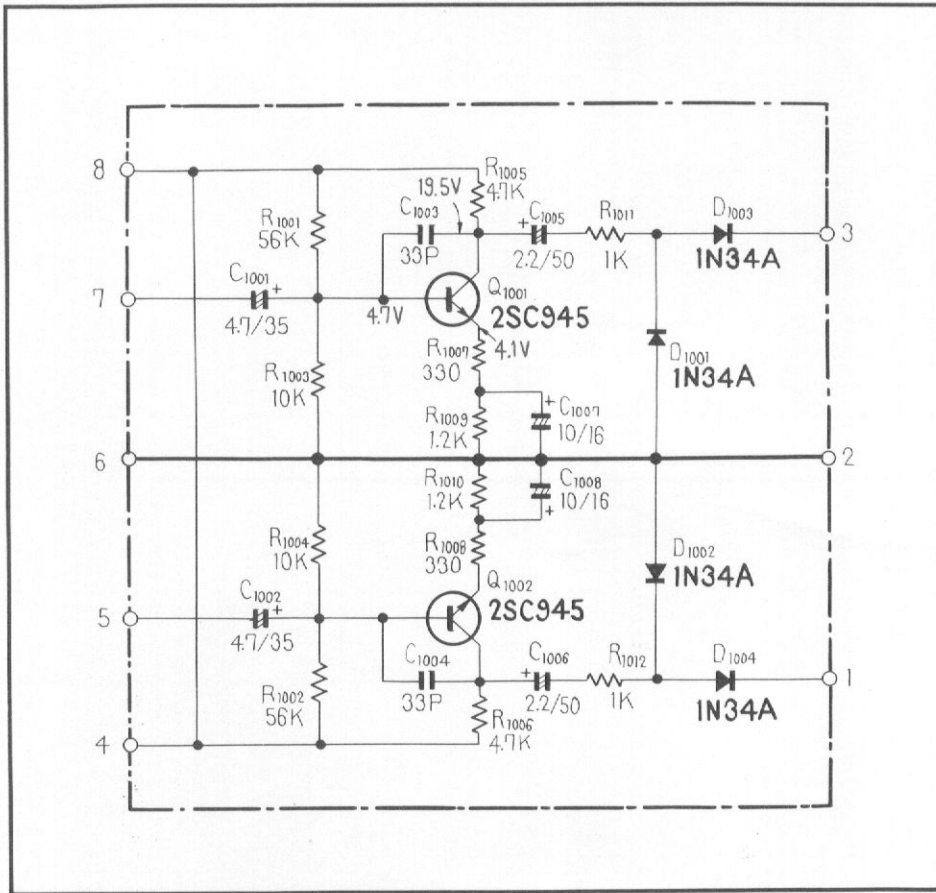

Parts List

CAPACITORS

Symbol	Description	Part No.
C1001	Electrolytic 4.7 35V	CEA 4R7P 35
C1002	Electrolytic 4.7 35V	CEA 4R7P 35
C1003	Ceramic 33p 50V	CCDSL 330K 50
C1004	Ceramic 33p 50V	CCDSL 330K 50
C1005	Electrolytic 2.2 50V	CEA 2R2P 50
C1006	Electrolytic 2.2 50V	CEA 2R2P 50
C1007	Electrolytic 10 16V	CEA 100P/6
C1008	Electrolytic 10 16V	CEA 100P/6

RESISTORS

Symbol	Description	Part No.
R1001	Carbon film 56k	RD¼PS 563J
R1002	Carbon film 56k	RD¼PS 563J
R1003	Carbon film 10k	RD¼PS 103J
R1004	Carbon film 10k	RD¼PS 103J
R1005	Carbon film 4.7k	RD¼PS 472J
R1006	Carbon film 4.7k	RD¼PS 472J
R1007	Carbon film 330	RD¼PS 331J
R1008	Carbon film 330	RD¼PS 331J

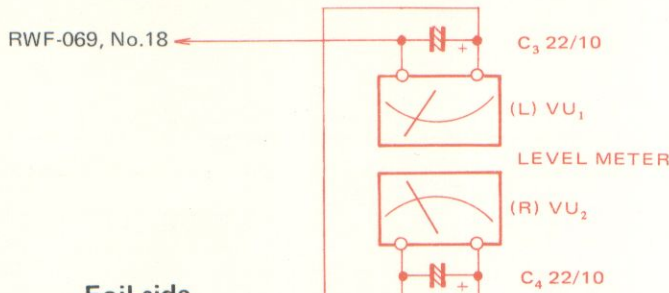

Foil side

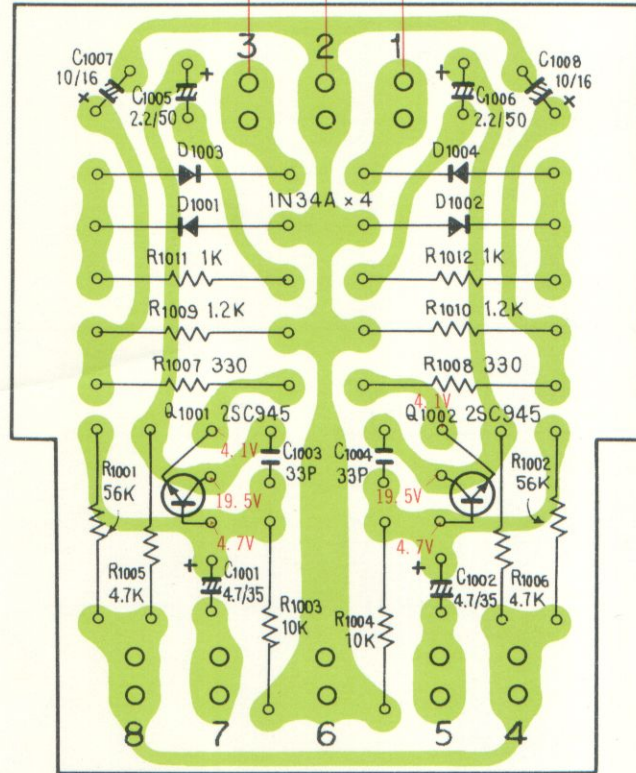

SEMICONDUCTORS

Symbol	Description	Part No.	Symbol	Description	Part No.
R1009	Carbon film 1.2k	RD¼PS 122J	Q1001	Transistor	2SC945P or Q
R1010	Carbon film 1.2k	RD¼PS 122J	Q1002	Transistor	2SC945P or Q
R1011	Carbon film 1k	RD¼PS 102J	D1001	Diode	1N 34A
R1012	Carbon film 1k	RD¼PS 102J	D1002	Diode	1N 34A
			D1003	Diode	1N 34A
			D1004	Diode	1N 34A

13.7 POWER AND OSCILLATION ASSEMBLY (RWR-053)

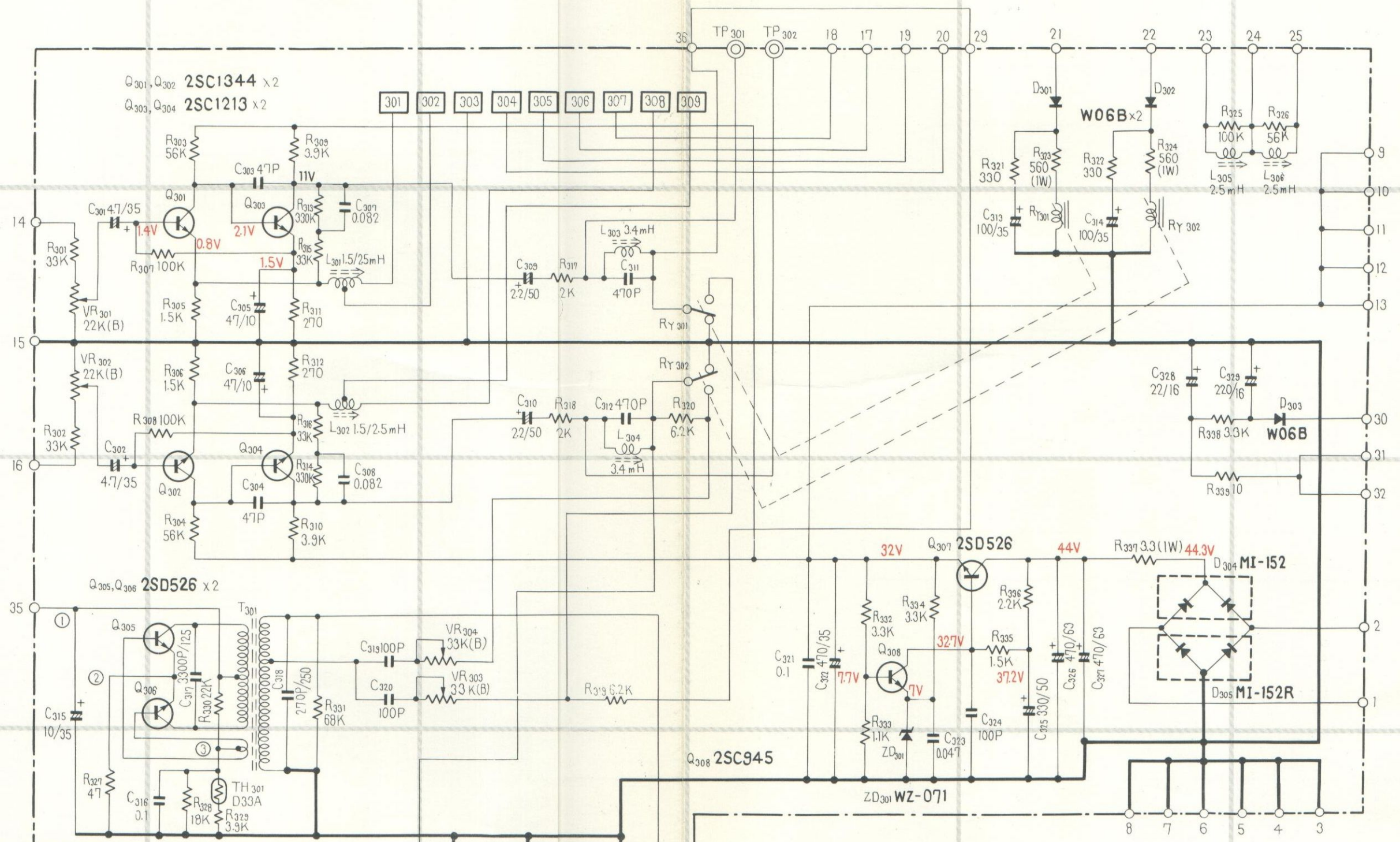

		①	②	③
STD	19cm/s	26.7V	2.9V	2.7V
	9.5cm/s	22V	2.2V	2.2V
LH	19cm/s	31.7V	3.5V	3.1V
	9.5cm/s	24.9V	2.6V	2.5V

1 2 3 4 5 6

Foil side

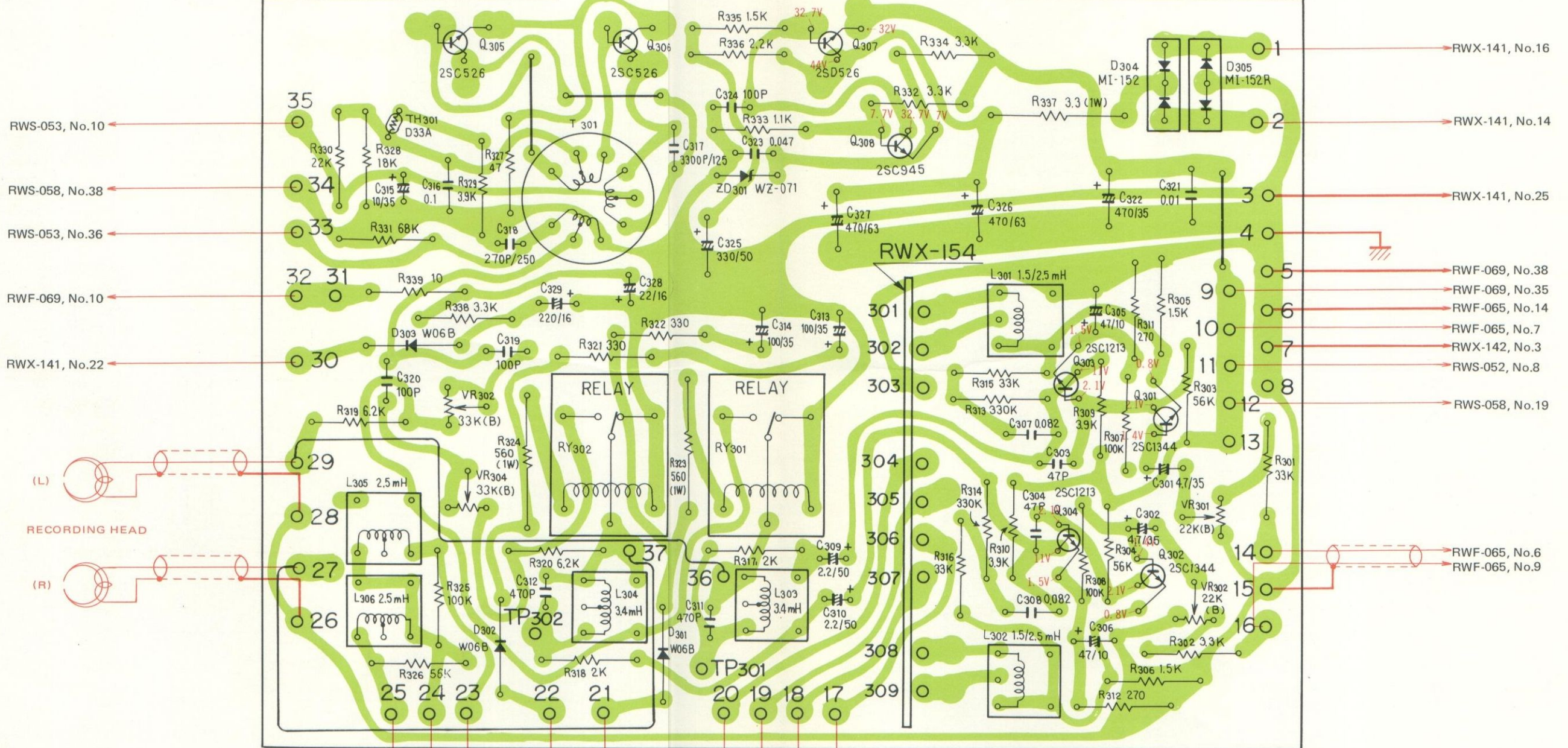

RWS-053, No.10
 RWS-058, No.38
 RWS-053, No.36

RWF-069, No.10
 RWX-141, No.22

RWF-069, No.38
 RWF-069, No.35
 RWF-065, No.14
 RWF-065, No.7
 RWX-142, No.3
 RWS-052, No.8
 RWS-058, No.19

(L)
 RECORDING HEAD
 (R)

RWX-141, No.16
 RWX-141, No.14

RWX-141, No.25

RWF-069, No.38
 RWF-069, No.35
 RWF-065, No.14
 RWF-065, No.7
 RWX-142, No.3
 RWS-052, No.8
 RWS-058, No.19

RWF-065, No.6
 RWF-065, No.9

RWS-058, No.29
 RWS-058, No.31
 RWS-058, No.37
 RWS-058, No.25
 RWS-058, No.26

RWS-058, No.20
 RWS-058, No.21
 RWS-058, No.23
 RWS-058, No.22

1 2 3 4 5 6

Parts List of Power and Oscillation Assembly (RWR-053)

TRANSFORMER, COILS

Symbol	Description	Part No.	Symbol	Description	Part No.
T301	OSC transformer	RTD-013	R301	Carbon film	33k
L301	Peaking coil	RTF-014	R302	Carbon film	33k
L302	Peaking coil	RTF-014	R303	Carbon film	56k
L303	Trap coil	RTF-013	R304	Carbon film	56k
L304	Trap coil	RTF-013	R305	Carbon film	1.5k
L305	Dummy coil	RTD-014	R306	Carbon film	1.5k
L306	Dummy coil	RTD-104	R307	Carbon film	100k
			R308	Carbon film	100k
			R309	Carbon film	3.9k
			R310	Carbon film	3.9k

CAPACITORS

Symbol	Description	Part No.	Symbol	Description	Part No.	
C301	Electrolytic	4.7 35V	CEA 4R7P 35	R311	Carbon film	270
C302	Electrolytic	4.7 35V	CEA 4R7P 35	R312	Carbon film	270
C303	Ceramic	47p 50V	CCDSL 470K 50	R313	Carbon film	330k
C304	Ceramic	47p 50V	CCDSL 470K 50	R314	Carbon film	330k
C305	Electrolytic	47 10V	CEA 470P 10	R315	Carbon film	33k
C306	Electrolytic	47 10V	CEA 470P 10	R316	Carbon film	33k
C307	Mylar	0.082 50V	CQMA 823K 50	R317	Carbon film	2k
C308	Mylar	0.082 50V	CQMA 823K 50	R318	Carbon film	2k
C309	Electrolytic	2.2 50V	CEA 2R2P 50	R319	Carbon film	6.2k
C310	Electrolytic	2.2 50V	CEA 2R2P 50	R320	Carbon film	6.2k
C311	Styrol	470p 50V	CQSA 471K 50	R321	Carbon film	330
C312	Styrol	470p 50V	CQSA 471K 50	R322	Carbon film	330
C313	Electrolytic	100 35V	CEA 101P 35	R323	Metal oxide	560
C314	Electrolytic	100 35V	CEA 101P 35	R324	Metal oxide	560
C315	Electrolytic	10 35V	CEA 100P 35	R325	Carbon film	100k
C316	Mylar	0.1 50V	CQMA 104K 50	R326	Carbon film	56k
C317	Styrol	0.0033 125V	CQSA 332J 125	R327	Carbon film	47
C318	Styrol	270p 250V	CQSA 271J 250	R328	Carbon film	18k
C319	Styrol	100p 50V	CQSA 101K 50	R329	Carbon film	3.9k
C320	Styrol	100p 50V	CQSA 101K 50	R330	Carbon film	22k
C321	Mylar	0.1 50V	CQMA 104K 50	R331	Carbon film	68k
C322	Electrolytic	470 35V	CEA 471P 35	R332	Carbon film	3.3k
C323	Ceramic	0.047 50V	CKDYF 473Z 50	R333	Carbon film	1.1k
C324	Ceramic	100p 50V	CCDSL 101K 50	R334	Carbon film	3.3k
C325	Electrolytic	330 50V	CEA 331P 50	R335	Carbon film	1.5k
C326	Electrolytic	470 63V	CEA 471P 63	R336	Carbon film	2.2k
C327	Electrolytic	470 63V	CEA 471P 63	R337	Metal oxide	3.3
C328	Electrolytic	22 16V	CEA 220P 16	R338	Carbon film	3.3k
C329	Electrolytic	220 16V	CEA 221P 16	R339	Carbon film	10

SEMICONDUCTORS

RESISTORS

Symbol	Description	Part No.
VR301	Semi fixed	22k-B
VR302	Semi fixed	22k-B
VR303	Semi fixed	33k-B
VR304	Semi fixed	33k-B

Symbol	Description	Part No.
Q301	Transistor	2SC1344-D or 2SC1344-E
Q302	Transistor	2SC1344-D or 2SC1344-E
Q303	Transistor	2SC1213-B or 2SC1213-C

<u>Symbol</u>	<u>Description</u>	<u>Part No.</u>	<u>Symbol</u>	<u>Description</u>	<u>Part No.</u>
Q304	Transistor	2SC1213-B or 2SC1213-C	ZD301	Zener Diode	WZ-071
Q305	Transistor	2SD526-0	TH301	Thermistor	D33A
Q306	Transistor	2SD526-0	OTHERS		
Q307	Transistor	2SD526-0 or 2SD526-Y			
Q308	Transistor	2SC945-P or 2SC945-Q	<u>Symbol</u>	<u>Description</u>	<u>Part No.</u>
D301	Diode	W06B		Heat Sink	RNF-065
D302	Diode	W06B		Tr socket	AKH-002
D303	Diode	W06B	RY301	Insulator	REE-051
D304	Diode	MI-152	RY302	Relay	RSP-018
D305	Diode	MI-152R		Relay	RSP-018

13.8 INDICATOR ASSEMBLY (RWX-142)

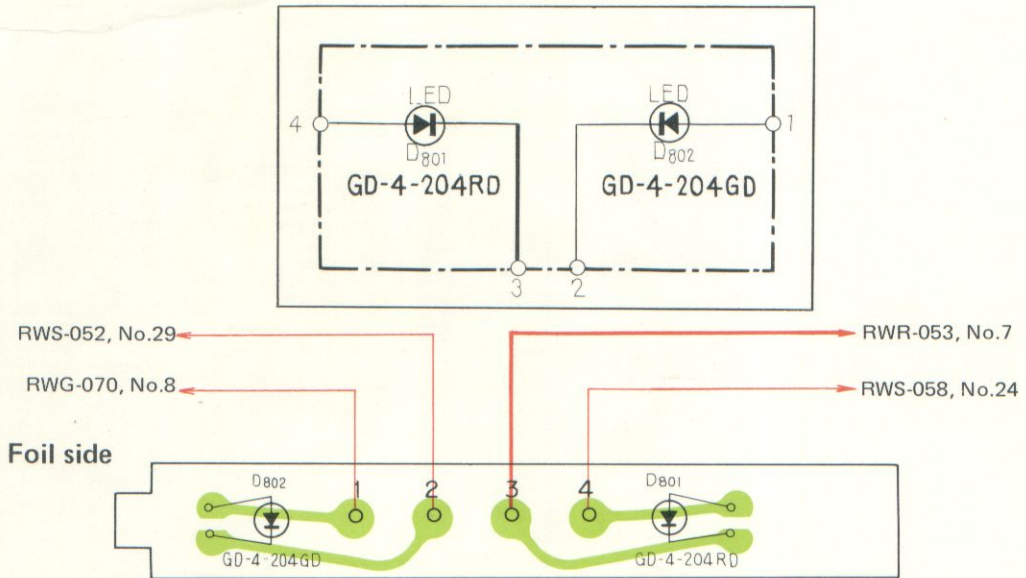

Parts List

SEMICONDUCTORS

<u>Symbol</u>	<u>Description</u>	<u>Part No.</u>
D801	Light emitting diode	GD-4-204RD
D802	Light emitting diode	GD-4-204GD
	Diode holder	REB-204

13.9 FUSE ASSEMBLY (RWX-141)

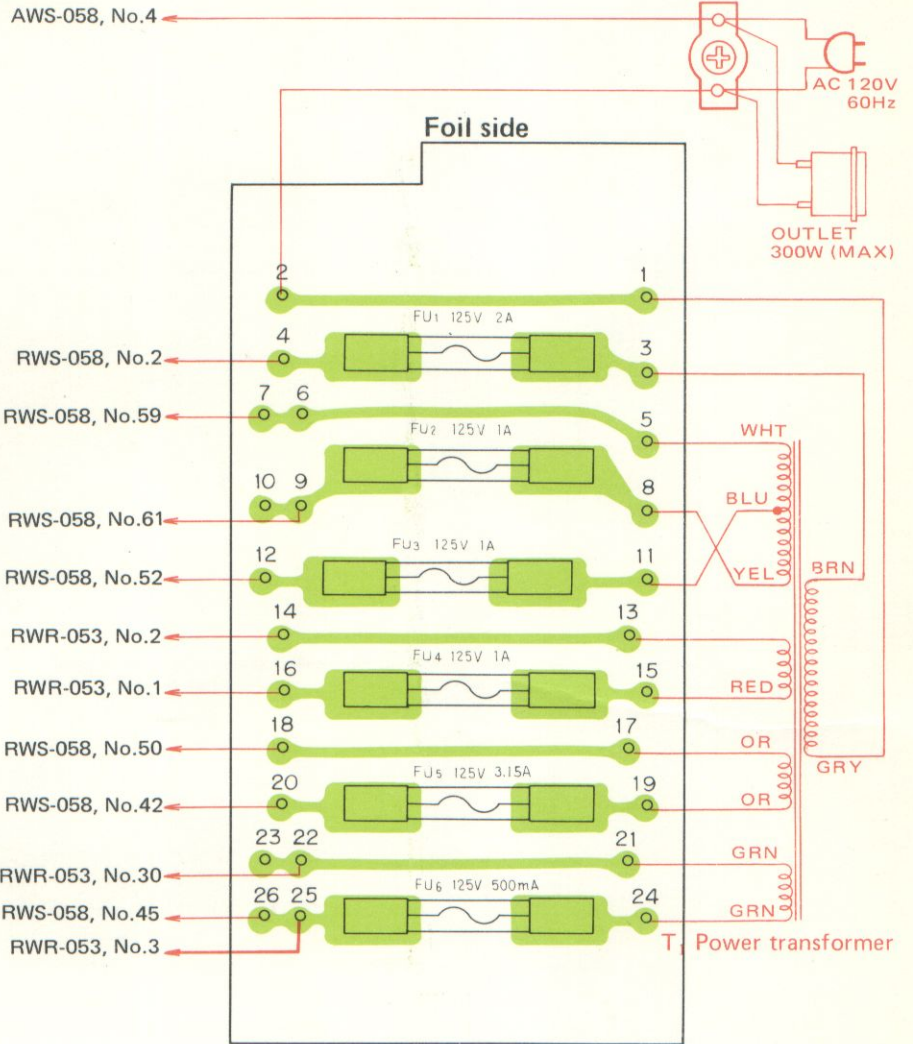
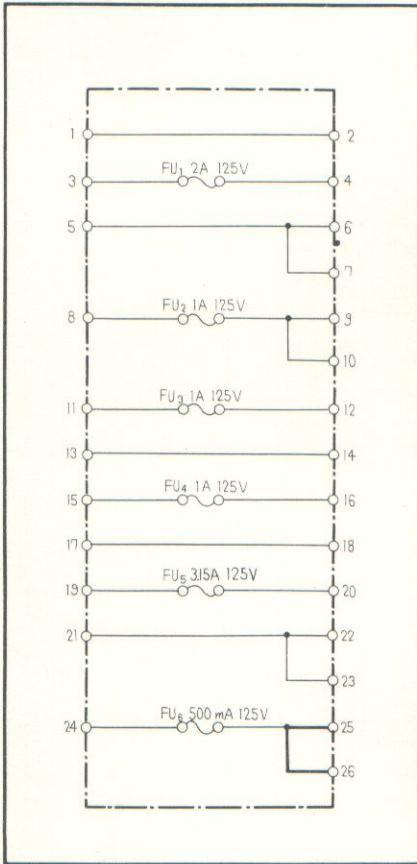

Parts List

Symbol	Description	Part No.
FU1	Fuse 2A	REK-055
FU2	Fuse 1A	REK-051
FU3	Fuse 1A	REK-051
FU4	Fuse 1A	REK-051
FU5	Fuse 3.15A	REK-044
FU6	Fuse 0.5A	REK-048
	Fuse clip	RKR-017

13.10 EQUALIZER AMPLIFIER ASSEMBLY (RWX-154)

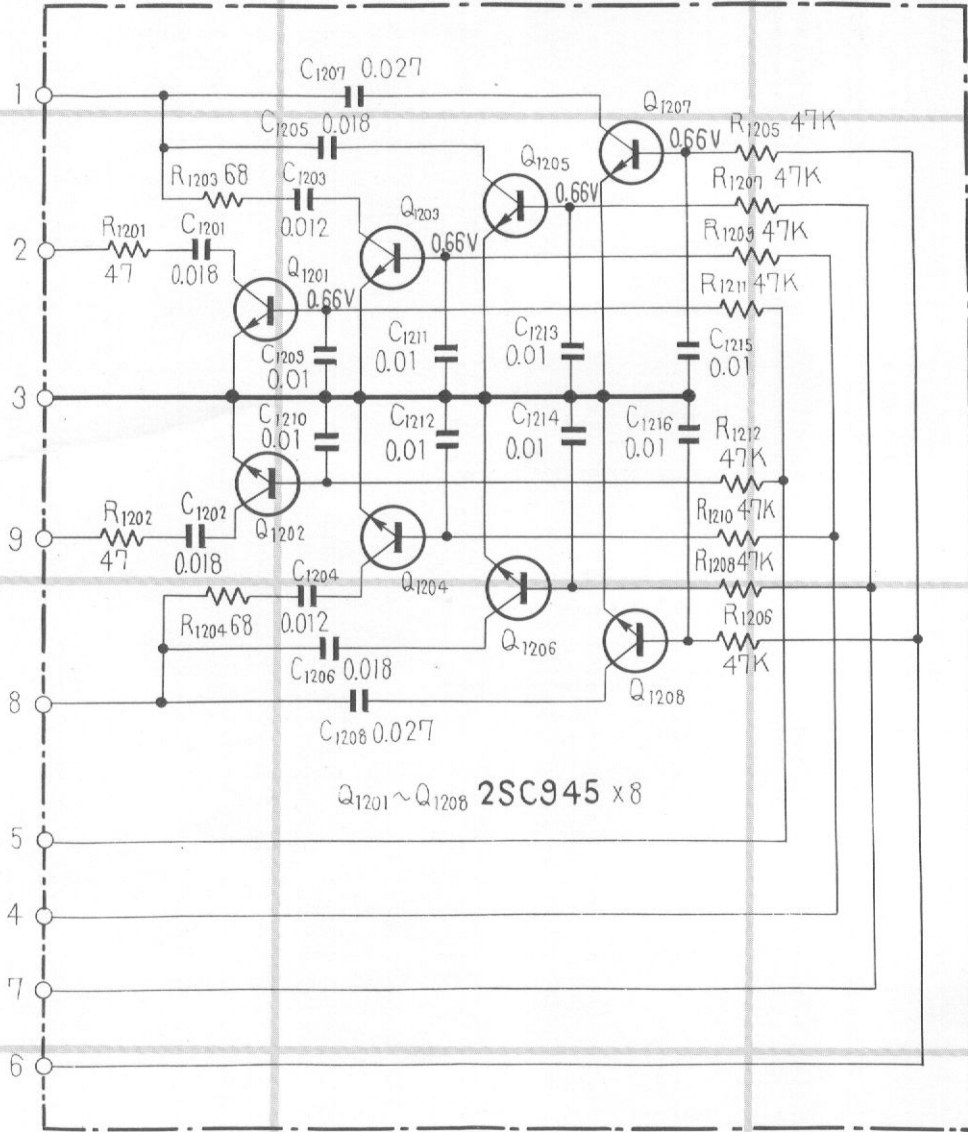

Foil side

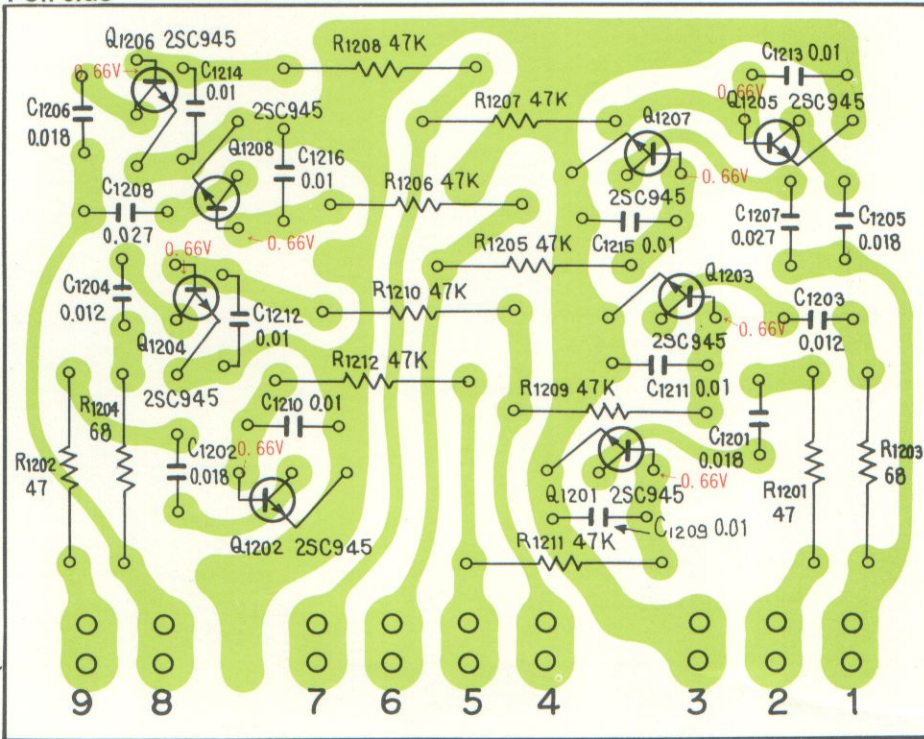

ON POWER AND OSCILLATION ASSEMBLY (RWR-053)

Parts List

CAPACITORS

Symbol	Description	Part No.
C1201	Mylar 0.018 50V	CQMA 183K 50
C1202	Mylar 0.018 50V	CQMA 183K 50
C1203	Mylar 0.012 50V	CQMA 123K 50
C1204	Mylar 0.012 50V	CQMA 123K 50
C1205	Mylar 0.018 50V	CQMA 183K 50
C1206	Mylar 0.018 50V	CQMA 183K 50
C1207	Mylar 0.027 50V	CQMA 273K 50
C1208	Mylar 0.027 50V	CQMA 273K 50
C1209	Ceramic 0.01 50V	CKDYF 103Z 50
C1210	Ceramic 0.01 50V	CKDYF 103Z 50
C1211	Ceramic 0.01 50V	CKDYF 103Z 50
C1212	Ceramic 0.01 50V	CKDYF 103Z 50
C1213	Ceramic 0.01 50V	CKDYF 103Z 50
C1214	Ceramic 0.01 50V	CKDYF 103Z 50
C1215	Ceramic 0.01 50V	CKDYF 103Z 50
C1216	Ceramic 0.01 50V	CKDYF 103Z 50

Symbol	Description	Part No.
R1203	Carbon film 68	RD¼PS 680J
R1204	Carbon film 68	RD¼PS 680J
R1205	Carbon film 47k	RD¼PS 473J
R1206	Carbon film 47k	RD¼PS 473J
R1207	Carbon film 47k	RD¼PS 473J
R1208	Carbon film 47k	RD¼PS 473J
R1209	Carbon film 47k	RD¼PS 473J
R1210	Carbon film 47k	RD¼PS 473J
R1211	Carbon film 47k	RD¼PS 473J
R1212	Carbon film 47k	RD¼PS 473J

SEMICONDUCTORS

Symbol	Description	Part No.
Q1201	Transistor	2SC945P or Q
Q1202	Transistor	2SC945P or Q
Q1203	Transistor	2SC945P or Q
Q1204	Transistor	2SC945P or Q
Q1205	Transistor	2SC945P or Q
Q1206	Transistor	2SC945P or Q
Q1207	Transistor	2SC945P or Q
Q1208	Transistor	2SC945P or Q

RESISTORS

Symbol	Description	Part No.
R1201	Carbon film 47	RD¼PS 470J
R1202	Carbon film 47	RD¼PS 470J

13.11 HEAD AMPLIFIER ASSEMBLY (RWF-070)

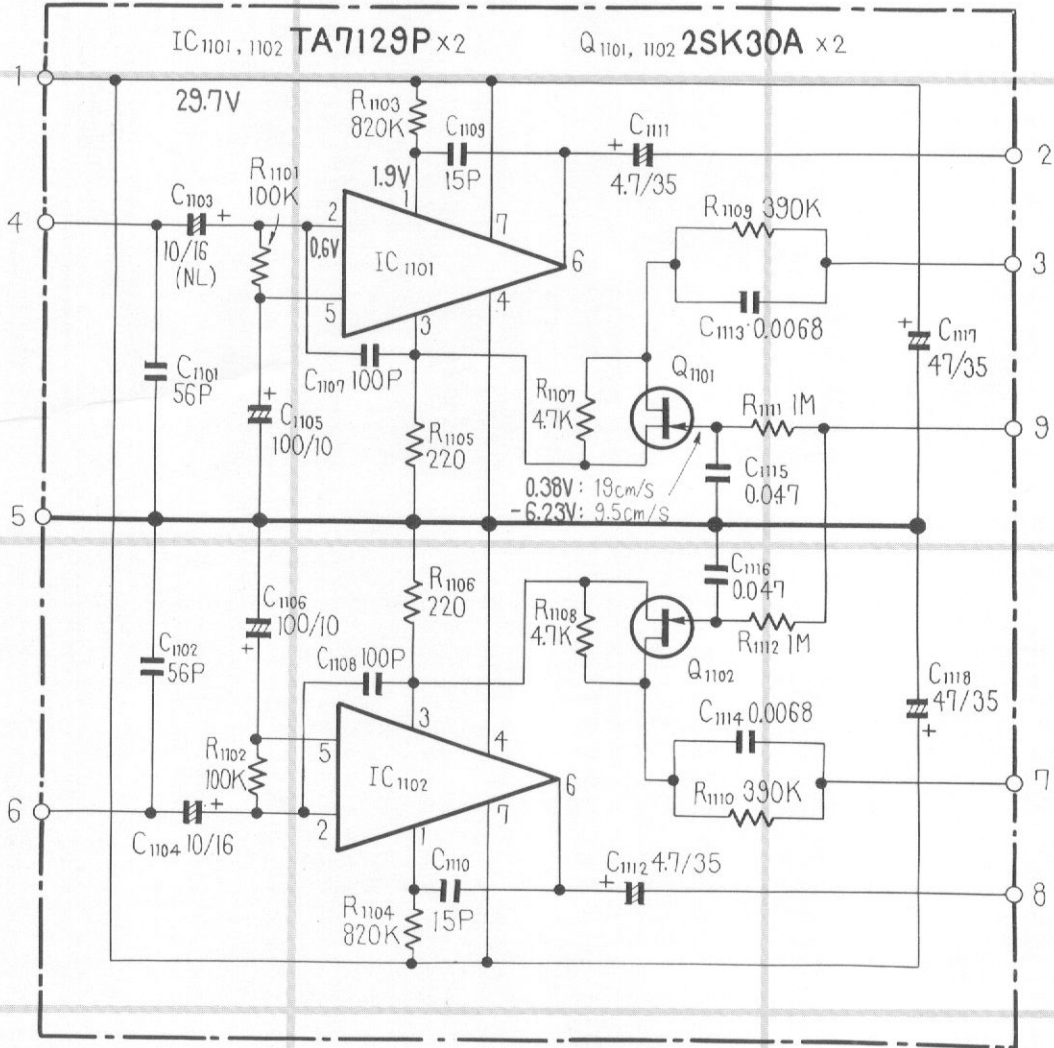

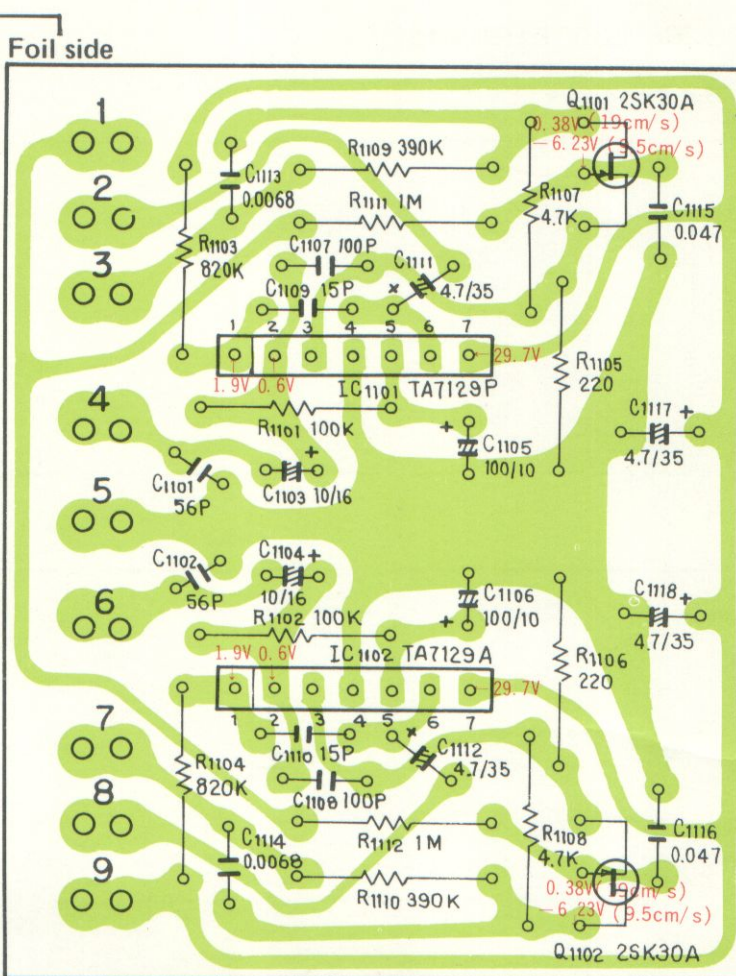

ON PLAYBACK AMPLIFIER ASSEMBLY (RWF-069)

Parts List

CAPACITORS

Symbol	Description	Part No.
C1101	Polystyrene 56p 50V	RCE-004
C1102	Polystyrene 56p 50V	RCE-004
C1103	Electrolytic 10 16V	RCH-018
C1104	Electrolytic 10 16V	RCH-018
C1105	Electrolytic 100 10V	CEA 101P 10
C1106	Electrolytic 100 10V	CEA 101P 10
C1107	Ceramic 100p 50V	CCDSL 101K 50
C1108	Ceramic 100p 50V	CCDSL 101K 50
C1109	Ceramic 15p 50V	CCDSL 150K 50
C1110	Ceramic 15p 50V	CCDSL 150K 50
C1111	Electrolytic 4.7 35V	CEA 4R7P 35
C1112	Electrolytic 4.7 35V	CEA 4R7P 35
C1113	Mylar 6800p 50V	CQMA 682K 50
C1114	Mylar 6800p 50V	CQMA 682K 50
C1115	Ceramic 0.047 50V	CKDYF 473Z 50
C1116	Ceramic 0.047 50V	CKDYF 473Z 50
C1117	Electrolytic 47 35V	CEA 470P 35
C1118	Electrolytic 47 35V	CEA 470P 35

RESISTORS

Symbol	Description	Part No.
R1101	Carbon film 100k	RD¼PS 104J
R1102	Carbon film 100k	RD¼PS 104J
R1103	Carbon film 820k	RD¼PS 824J
R1104	Carbon film 820k	RD¼PS 824J
R1105	Carbon film 220	RD¼PS 221J
R1106	Carbon film 220	RD¼PS 221J
R1107	Carbon film 4.7k	RD¼PS 472J
R1108	Carbon film 4.7k	RD¼PS 472J
R1109	Carbon film 390k	RD¼PS 394J
R1110	Carbon film 390k	RD¼PS 394J
R1111	Carbon film 1M	RD¼PS 105J
R1112	Carbon film 1M	RD¼PS 105J

SEMICONDUCTORS

Symbol	Description	Part No.
IC1161	IC	TA7129P
IC1102	IC	TA7129P
Q1101	FET	2SK30A-Y or O
Q1102	FET	2SK30A-Y or O

13.12 CONNECTOR ASSEMBLY L (RWX-151)

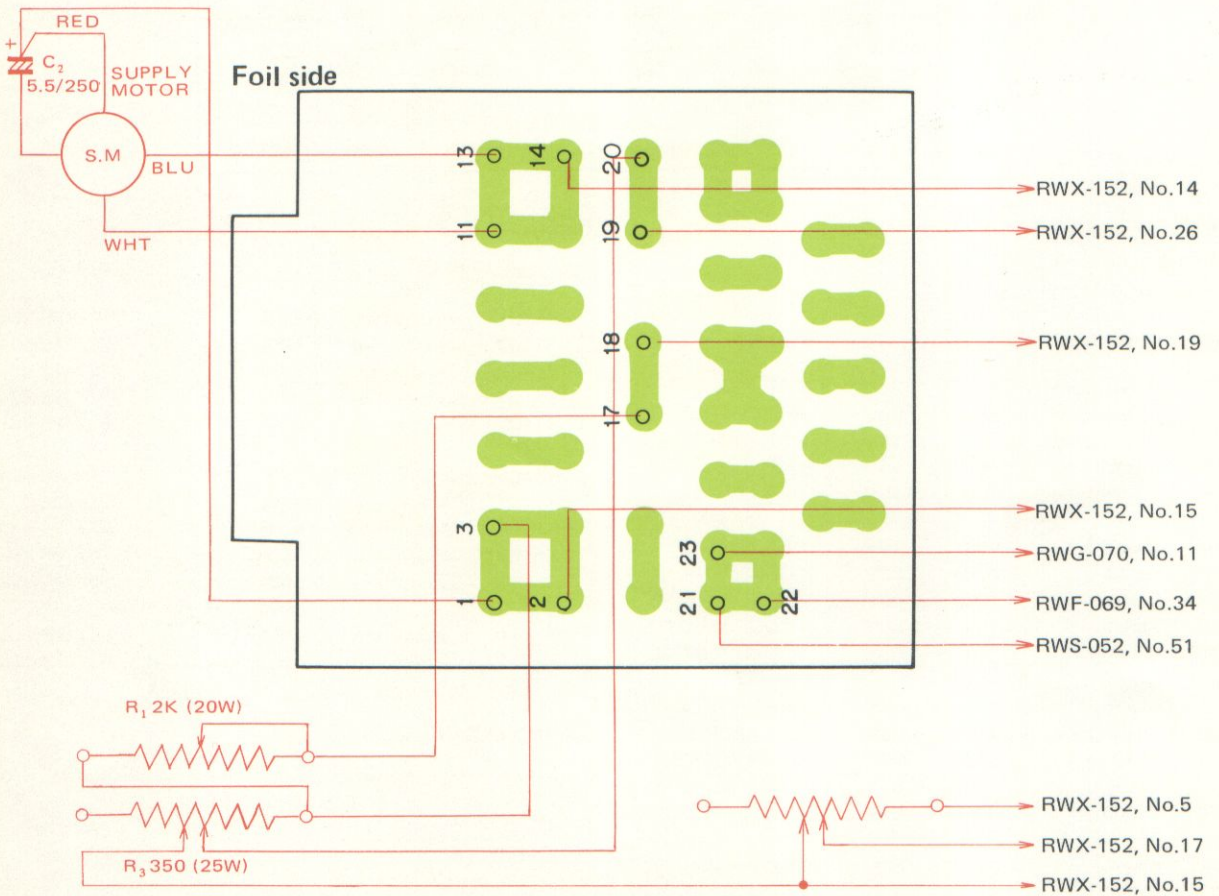
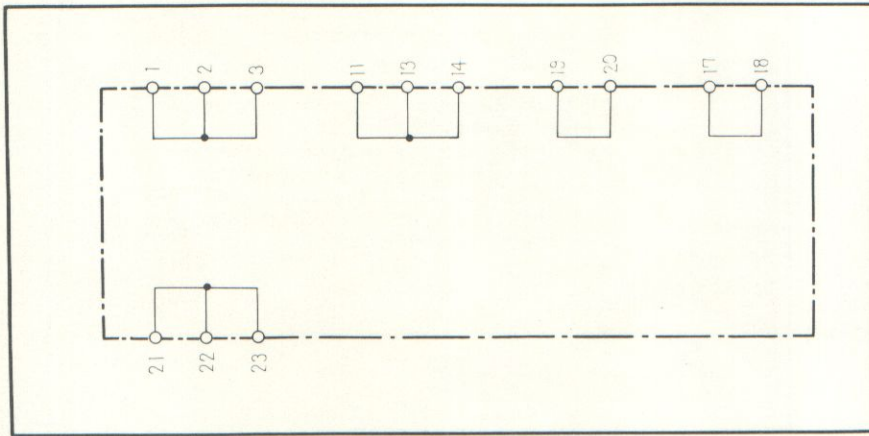

13.13 CONNECTOR ASSEMBLY R (RWX-152)

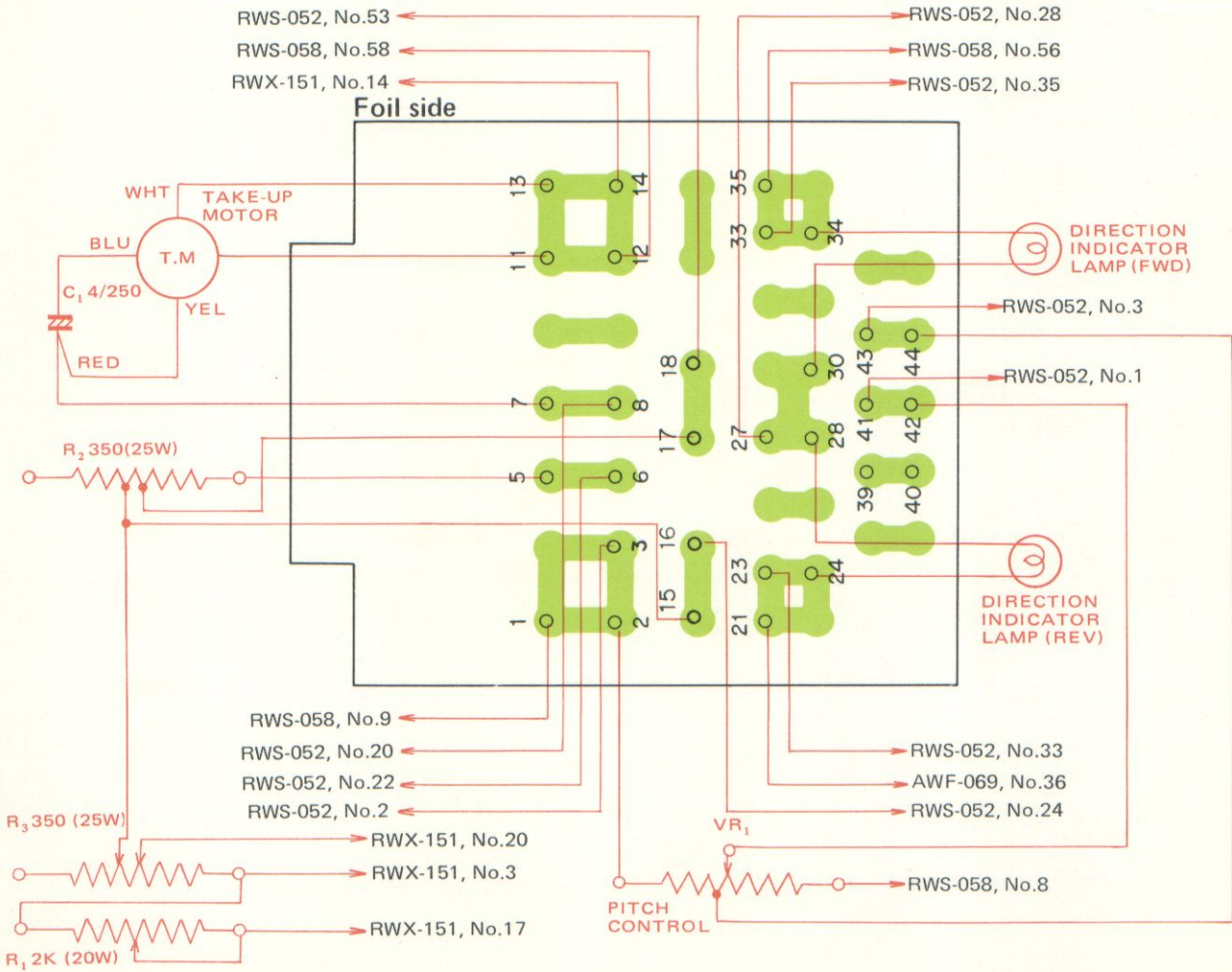
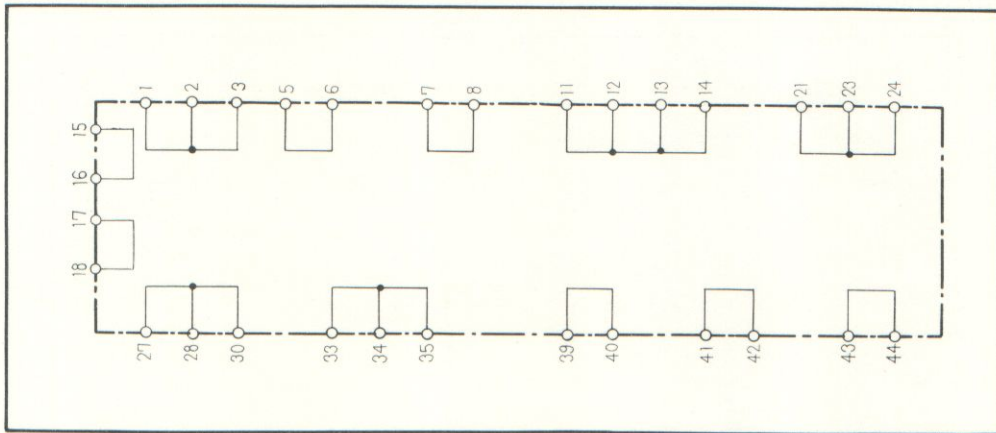

13.14 FUNCTION SWITCH ASSEMBLY (RWS-052)

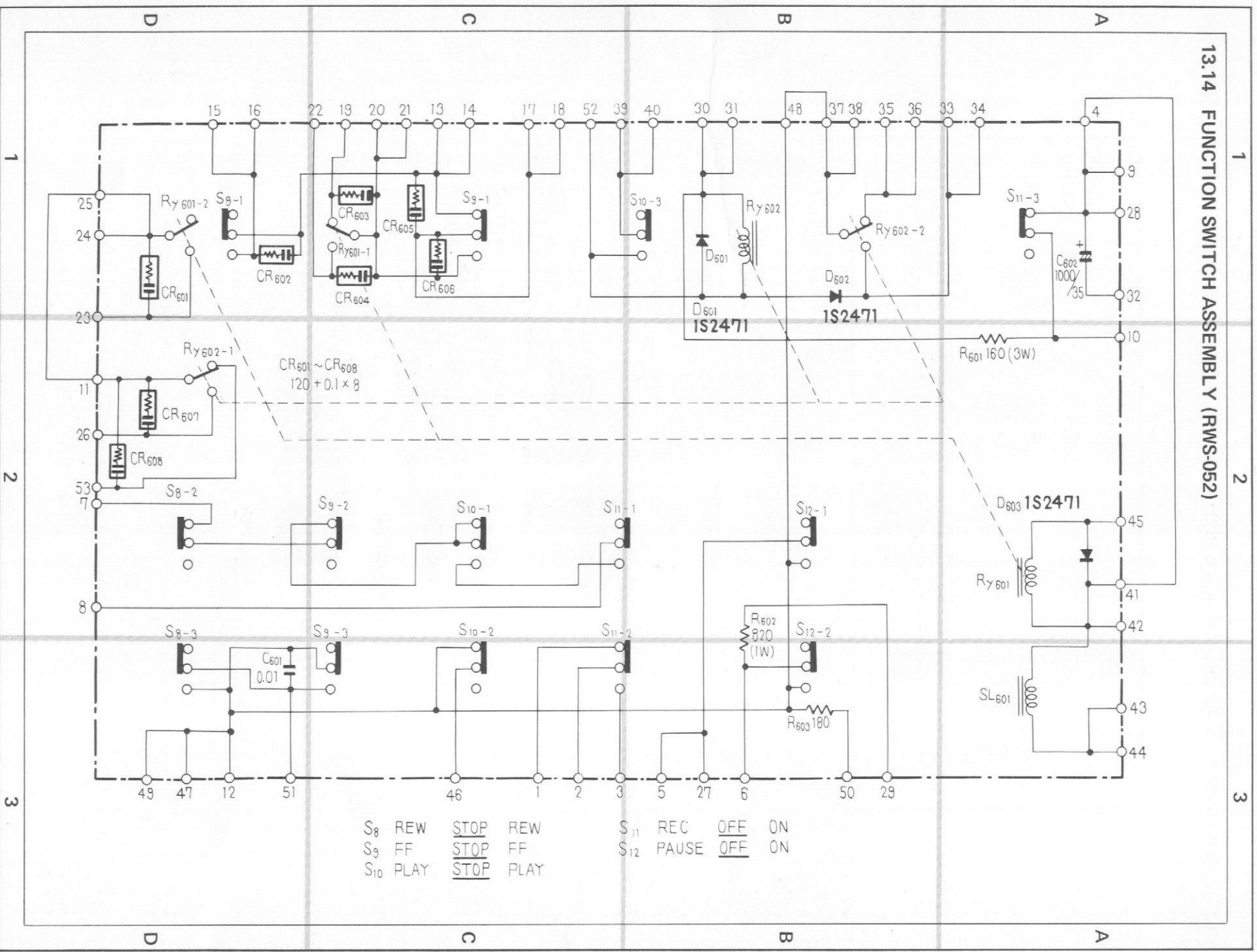

S ₈	REW	<u>STOP</u>	REW	S ₁₁	REC	<u>OFF</u>	ON
S ₉	FF	<u>STOP</u>	FF	S ₁₂	PAUSE	<u>OFF</u>	ON
S ₁₀	PLAY	<u>STOP</u>	PLAY				

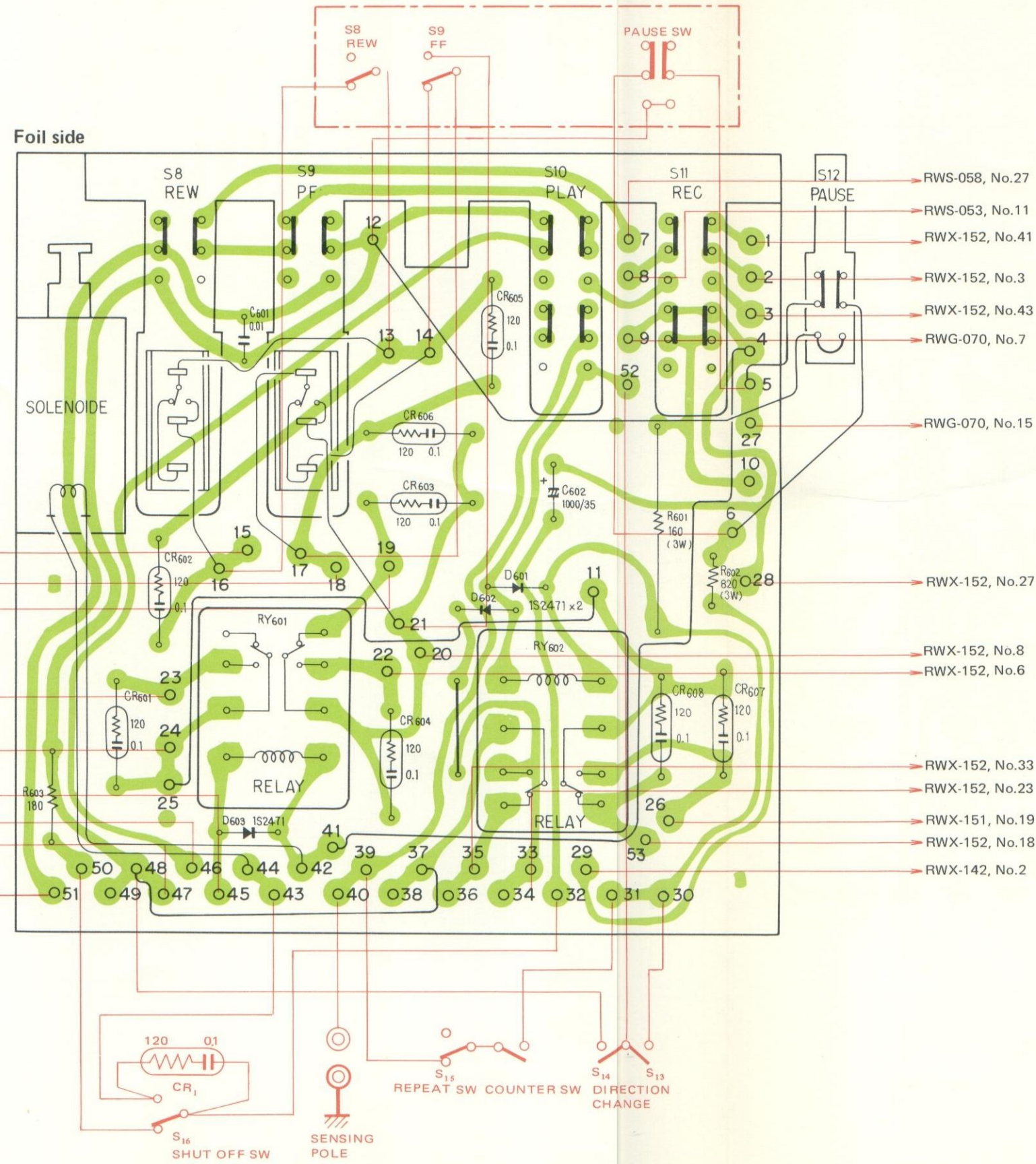

Parts List

SWITCHES

Symbol	Description	Part No.
S8	Switch (FUNCTION)	RSG-050
S9	Switch (FUNCTION)	RSG-050
S10	Switch (FUNCTION)	RSG-050
S11	Switch (FUNCTION)	RSG-050
S12	Switch (PAUSE)	RSG-048

CAPACITORS

Symbol	Description	Part No.
C601	Ceramic 0.01 50V	CKDYF 103Z 50
C602	Electrolytic 1,000 35V	CEA 102P 35

RESISTORS

Symbol	Description	Part No.
R601	Metal oxide 160 3W	RS3P 161J
R602	Metal oxide 820 1W	RS1P 821J
R603	Carbon film 180	RD¼PS 181J

SEMICONDUCTORS

Symbol	Description	Part No.
D601	Diode	1S2471
D602	Diode	1S2471
D603	Diode	1S2471

OTHERS

Symbol	Description	Part No.
RY601	Relay	RSR-016
RY602	Relay (12T)	RSR-022
CR601	Spark killer	RWX-030
CR602	Spark killer	RWX-030
CR603	Spark killer	RWX-030
CR604	Spark killer	RWX-030
CR605	Spark killer	RWX-030
CR606	Spark killer	RWX-030
CR607	Spark killer	RWX-030
CR608	Spark killer	RWX-030
	Bracket	RNF-052
	Release plate	RNF-084
	Release spring	RBH-152
	Solenoid (RELEASE)	RXP-042

13.15 MIC AMPLIFIER ASSEMBLY (RWF-065)

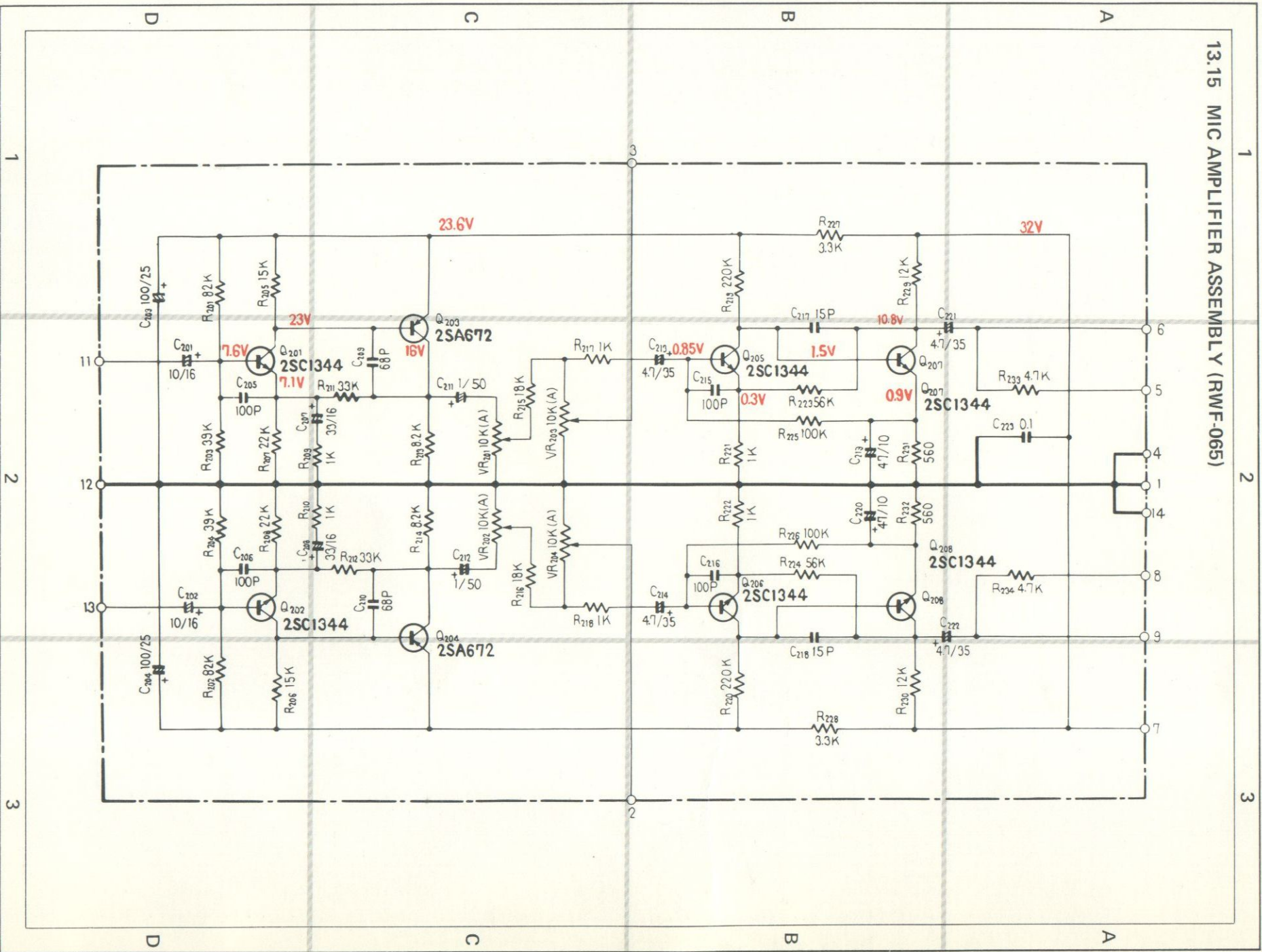

Foil side

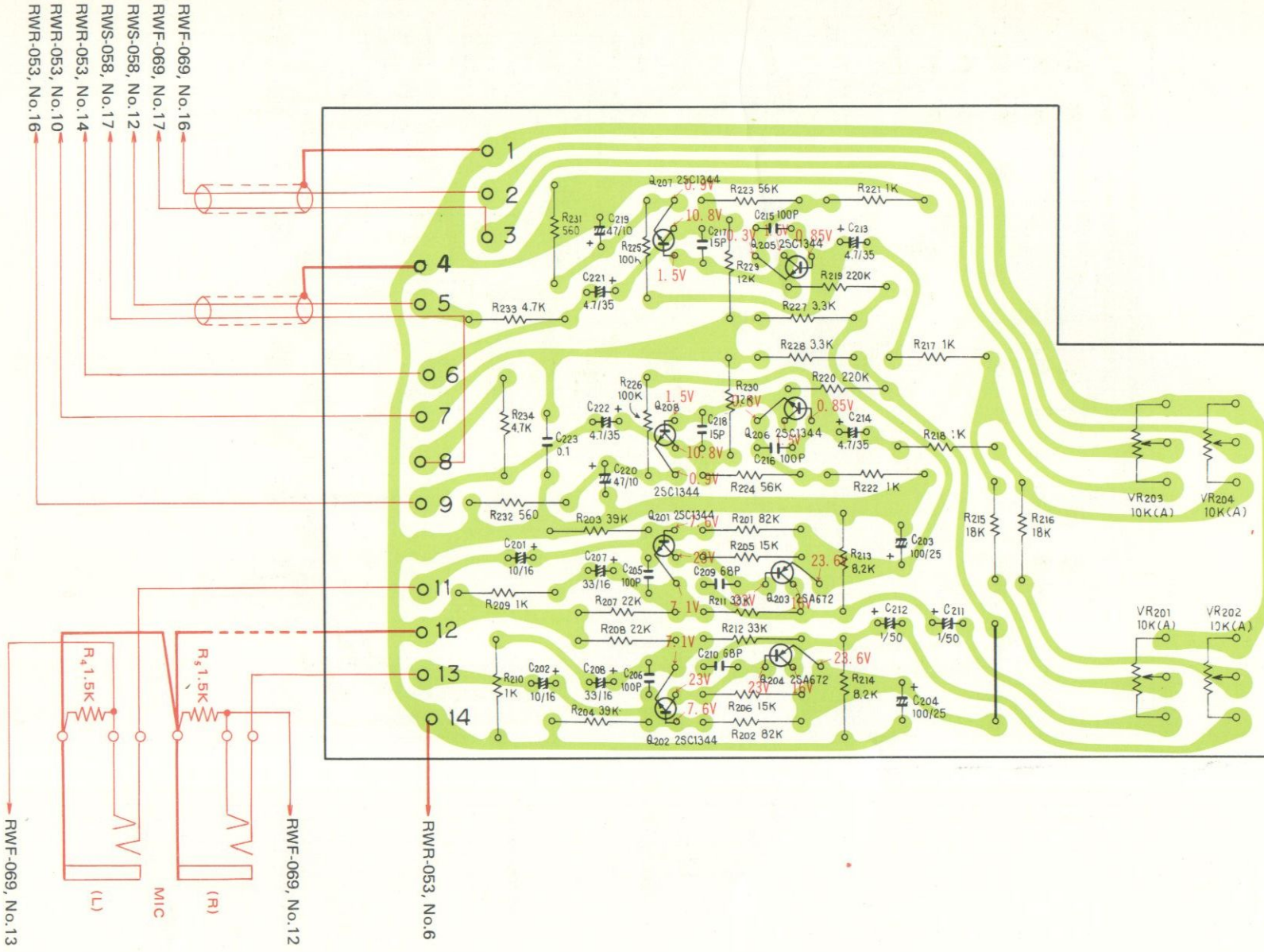

- RWF-069, No. 16
- RWF-069, No. 17
- RWS-058, No. 12
- RWS-058, No. 17
- RWR-053, No. 14
- RWR-053, No. 10
- RWR-053, No. 16

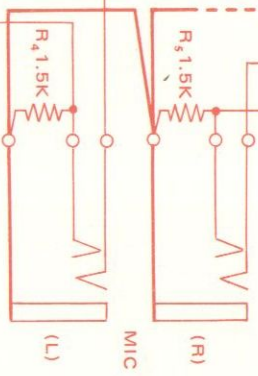

RWF-069, No. 13

RWF-069, No. 12

RWR-053, No. 6

1
2
3

1
2
3

D
C
B
A

Parts List

CAPACITORS

Symbol	Description	Part No.	Symbol	Description	Part No.
C201	Electrolytic 10 16V	RCH-018	R216	Carbon film 18k	RD¼PS 183J
C202	Electrolytic 10 16V	RCH-018	R217	Carbon film 1k	RD¼PS 102J
C203	Electrolytic 100 25V	CEA 101P 25	R218	Carbon film 1k	RD¼PS 102J
C204	Electrolytic 100 25V	CEA 101P 25	R219	Carbon film 220k	RD¼PS 224J
C205	Ceramic 100p 50V	CCDSL 101K 50	R220	Carbon film 220k	RD¼PS 224J
C206	Ceramic 100p 50V	CCDSL 101K 50	R221	Carbon film 1k	RD¼PS 102J
C207	Electrolytic 33 16V	CEA 330P 16	R222	Carbon film 1k	RD¼PS 102J
C208	Electrolytic 33 16V	CEA 330P 16	R223	Carbon film 56k	RD¼PS 563J
C209	Ceramic 68p 50V	CCASL 680K 50	R224	Carbon film 56k	RD¼PS 563J
C210	Ceramic 68p 50V	CCDSL 680K 50	R225	Carbon film 100k	RD¼PS 104J
C211	Electrolytic 1 50V	CEA 010P 50	R226	Carbon film 3.2k	RD¼PS 332J
C212	Electrolytic 1 50V	CEA 010P 50	R227	Carbon film 3.2k	RD¼PS 332J
C213	Electrolytic 4.7 35V	CEA 4R7P 35	R228	Carbon film 12k	RD¼PS 123J
C214	Electrolytic 4.7 35V	CEA 4R7P 35	R229	Carbon film 12k	RD¼PS 123J
C215	Ceramic 100p 50V	CCDSL 101K 50	R230	Carbon film 560	RD¼PS 561J
C216	Ceramic 15p 50V	CCDSL 150K 50	R232	Carbon film 560	RD¼PS 561J
C217	Ceramic 15p 50V	CCDSL 150K 50	R233	Carbon film 4.7k	RD¼PS 472J
C218	Ceramic 15p 50V	CCDSL 150K 50	R234	Carbon film 4.7k	RD¼PS 472J
C219	Electrolytic 47 10V	CEA 470P 10			
C220	Electrolytic 47 10V	CEA 470P 10			
C221	Electrolytic 4.7 35V	CEA 4R7P 35			
C222	Electrolytic 4.7 35V	CEA 4R7P 35			
C223	Mylar 0.1 50V	CQMA 104K 50			

SEMICONDUCTORS

Symbol	Description	Part No.
Q201	Transistor	2SC1344D or E
Q202	Transistor	2SC1344D or E
Q203	Transistor	2SA672B or C
Q204	Transistor	2SA672B or C
Q205	Transistor	2SC1344D or E
Q206	Transistor	2SC1344D or E
Q207	Transistor	2SC1344D or E
Q208	Transistor	2SC1344D or E

RESISTORS

Symbol	Description	Part No.
VR201	Variable resistor 10k-A	RCV-033
VR202	Variable resistor 10k-A	RCV-033
VR203	Variable resistor 10k-A	RCV-033
VR204	Variable resistor 10k-A	RCV-033
R201	Carbon film 82k	RD¼PS 823J
R202	Carbon film 82k	RD¼PS 823J
R203	Carbon film 39k	RD¼PS 393J
R204	Carbon film 39k	RD¼PS 393J
R205	Carbon film 15k	RD¼PS 153J
R206	Carbon film 15k	RD¼PS 153J
R207	Carbon film 22k	RD¼PS 223J
R208	Carbon film 22k	RD¼PS 223J
R209	Carbon film 1k	RD¼PS 102J
R210	Carbon film 1k	RD¼PS 102J
R211	Carbon film 33k	RD¼PS 333J
R212	Carbon film 33k	RD¼PS 333J
R213	Carbon film 8.2k	RD¼PS 822J
R214	Carbon film 8.2k	RD¼PS 822J
R215	Carbon film 18k	RD¼PS 183J

List of Changed Parts for Factory Modification

Symbol	Description	Part No.

13.16 CONTROL ASSEMBLY (RWG-070)

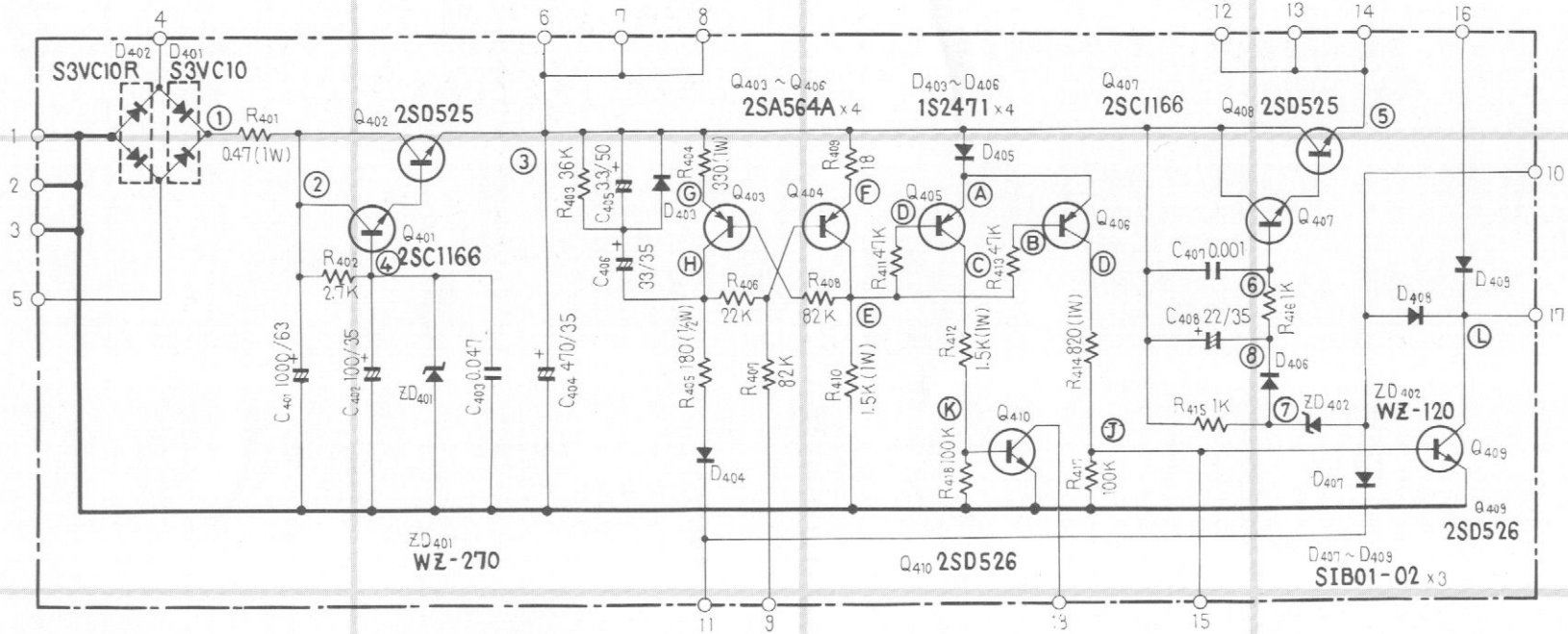

CONTROL

	(A)	(B)	(C)	(D)	(E)	(F)	(G)	(H)	(J)	(K)	(L)
STOP	25.5V	25.2V	0	0	25.4V	25.5V	25.8V	24.7V	0	0	25.5V
PLAY	24.4V	23.6V	24.3V	24.3V	1.8V	25.2V	25.2V	25.2V	0.8V	0.7V	0.3V
PLAY/REC	24.4V	23.6V	24.3V	24.3V	1.8V	25.2V	25.2V	25.2V	0.8V	0.7V	0.3V
FAST	25.3V	25.1V	0	0	25.2V	25.3V	25.6V	0.9V	0	0	25.5V
PLAY/PAUSE	24.8V	24.1V	24.7V	24.7V	1.8V	25.7V	25.6V	25.1V	0	0.7V	25.5V
REV											

POWER SUPPLY

	(1)	(2)	(3)	(4)	(5)	(6)	(7)	(8)
STOP	41V	40.7V	25.6V	27V	24.9V	25.5V	25.8V	25.5V
PLAY	33.6V	33V	25.2V	26.6V	11V	12.4V	12.9V	12.4V
FAST	38V	37.8V	25.4V	26.8V	11V	12.4V	12.7V	12.4V

1

2

3

A

A

- RWX-151, No.23
- RWS-052, No.46
- RWX-142, No.1
- RWS-052, No.9
- RWS-058, No.6
- RWS-058, No.43
- RWS-058, No.51
- RWS-052, No.47
- RWS-058, No.7

SL₁: Brake Solenoid SL₃: Pause Solenoid SL₂: Pinch Solenoid

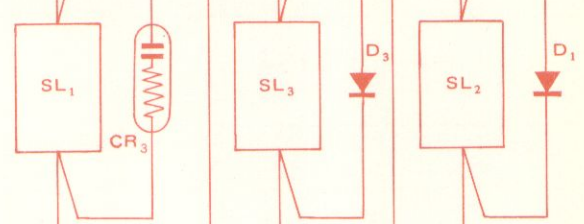

- RWS-052, No.27
- RWS-052, No.45

B

B

Foil side

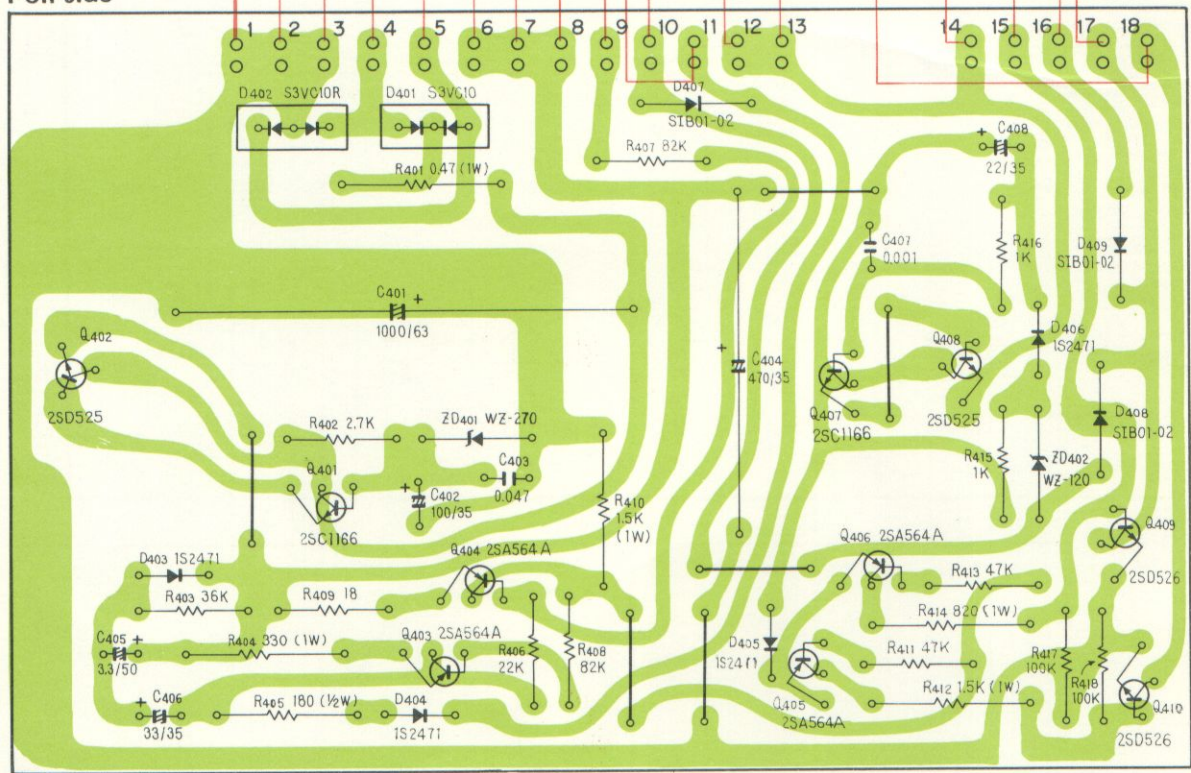

C

C

D

D

1

2

3

Parts List

CAPACITORS

<u>Symbol</u>	<u>Description</u>			<u>Part No.</u>
C401	Electrolytic	1000	63V	CEB 102P 63
C402	Electrolytic	100	35V	CEA 101 P 35
C403	Mylar	0.047	50V	CQMA 473K 50
C404	Electrolytic	470	35V	CEB 471P 35
C405	Electrolytic	3.3	50V	CEA 3R3P 50
C406	Electrolytic	33	35V	CEA 330P 35
C407	Mylar	0.001	50V	CQMA 102K 50
C408	Electrolytic	22	35V	CEA 220P 35

RESISTORS

<u>Symbol</u>	<u>Description</u>			<u>Part No.</u>
R401	Metal oxide	0.47	1W	RN1PSF R47J
R402	Carbon film	2.7k		RD¼PS 272J
R403	Carbon film	36k		RD¼PS 363J
R404	Metal oxide	330	1W	RD1PSF 331J
R405	Carbon film	180	½W	RD½PSF 181J
R406	Carbon film	22k		RD¼PS 223J
R407	Carbon film	82k		RD¼PS 823J
R408	Carbon film	82k		RD¼PS 823J
R409	Carbon film	18		RD¼PS 180J
R410	Metal oxide	1.5k	1W	RS1P 152J
R411	Carbon film	47k		RD¼PS 473J
R412	Metal oxide	1.5k	1W	RS1P 152J
R413	Carbon film	47k		RD¼PS 473J
R414	Metal oxide	820	1W	RS1P821J
R415	Carbon film	1k		RD¼PS 102J
R416	Carbon film	1k		RD¼PS 102J
R417	Carbon film	100k		RD¼PS 104J
R418	Carbon film	100k		RD¼PS 104J

SEMICONDUCTORS

<u>Symbol</u>	<u>Description</u>	<u>Part No.</u>
Q401	Transistor	2SC945 P or Q
Q402	Transistor	2SD525 O or Y
Q403	Transistor	2SA564A-R or S
Q404	Transistor	2SA564A-R or S
Q405	Transistor	2SA564A-R or S
Q406	Transistor	2SA564A-R or S
Q407	Transistor	2SC945 P or Q
Q408	Transistor	2SD525 O or Y
Q409	Transistor	2SD526 O or Y
Q410	Transistor	2SD526 O or Y
D401	Diode	S3VC10
D402	Diode	S3VC10 R
D403	Diode	1S2471
D404	Diode	1S2471
D405	Diode	1S2471

<u>Symbol</u>	<u>Description</u>	<u>Part No.</u>
D406	Diode	1S2471
D407	Diode	SIB01-02
D408	Diode	SIB01-02
D409	Diode	SIB01-02
ZD401	Zener Diode	WZ-270
ZD402	Zener Diode	WZ-120

OTHERS

<u>Symbol</u>	<u>Description</u>	<u>Part No.</u>
	Heat sink	RNF-083
	Insulator spacer	REE-051
	Tr socket	AKH-002

List of Changed Parts for Factory Modification

<u>Symbol</u>	<u>Description</u>	<u>Part No.</u>

13.17 SERVO AMPLIFIER ASSEMBLY (RWG-076)

NOTE:
The voltage at each measure points are indicated on page 99.

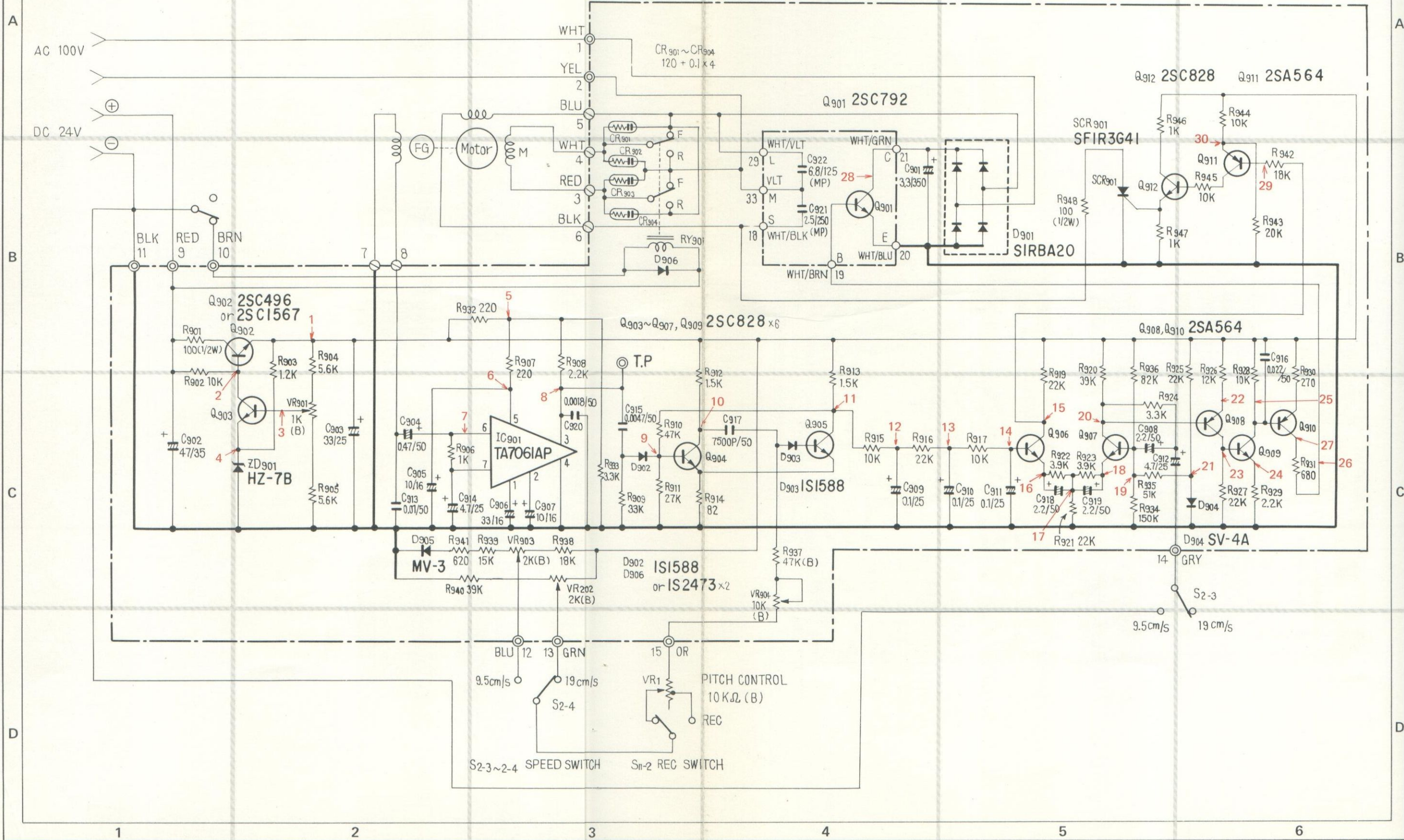

1 2 3 4 5 6

A

A

B

B

C

C

D

D

Foil side

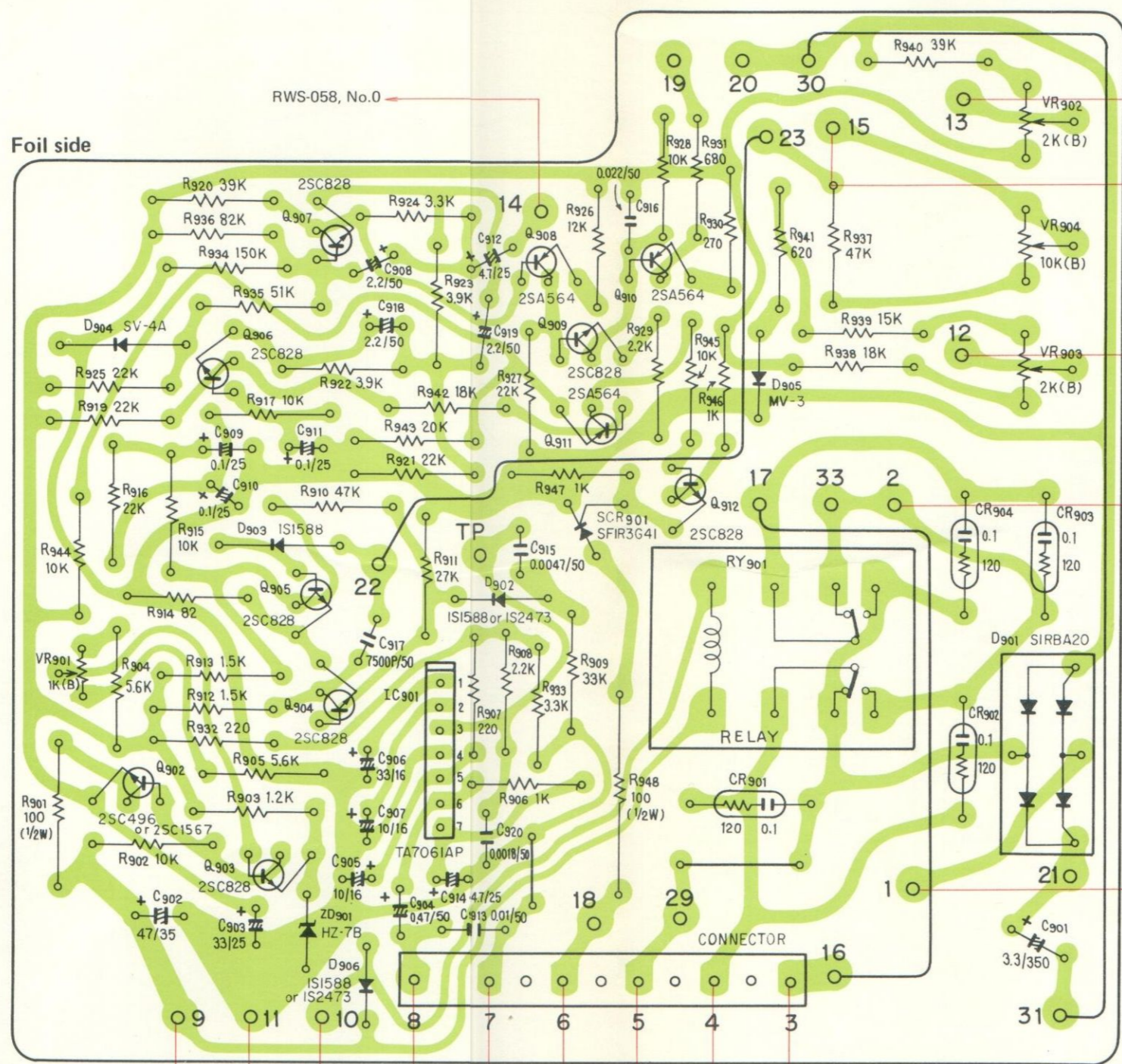

RWS-058, No.0

RWS-058, No.P

RWS-058, No.Q

RWS-058, No.R

RWS-058, No.B

RWS-058, No.A

RWS-058, No.E

RWS-058, No.G

RWS-058, No.F

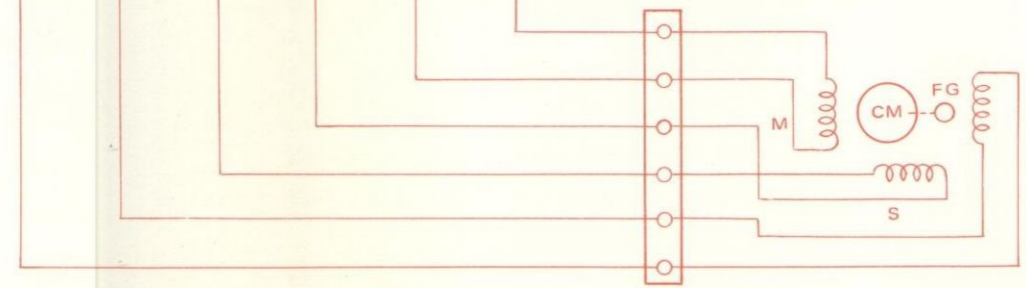

1 2 3 4 5 6

The Measurement Voltage of Servo Amplifier (RWG-076)

- The number of measurement points are indicated on page 95.
- The motor is non load situation.
- Prepare the high input impedance meter for measure the points 13 ~ 22.

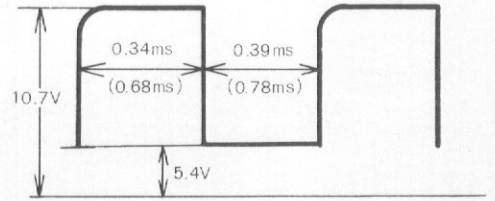

Fig. 37

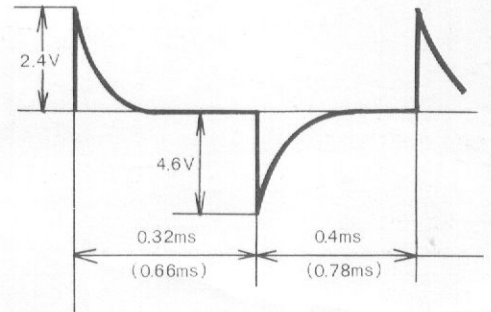

Fig. 38

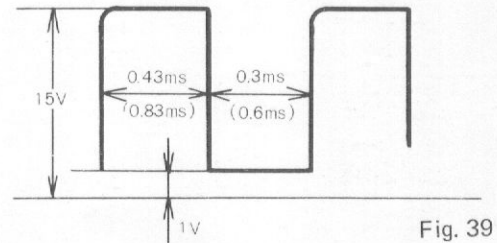

Fig. 39

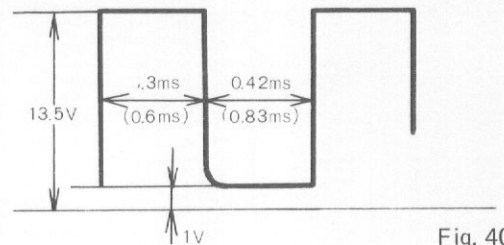

Fig. 40

Measurement point	Measurement Voltage (V)
1	15.0
2	15.6
3	7.7
4	7.0
5	10.8
6	7.6
7	2.0 (DC ingredient)
8	Fig. 37
9	Fig. 38
10	Fig. 39
11	Fig. 40
12	Fig. 41
13	6.1 (DC ingredient)
14	6.1 (DC ingredient)
15	10.8
16	5.6
17	4.8
18	4.9
19	5.5
20	14.1
21	1.42
22	14.8
23	0.7 (0.66)
24	0.14 (0.11)
25	14.6 (14.7)
26	0.71 (0.56)
27	15
28	Fig. 42
29	10.8
30	10.1
31	15.0

Parts List of Servo Amplifier Assembly (RWG-076)

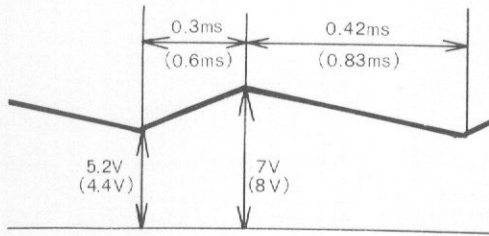

Fig. 41

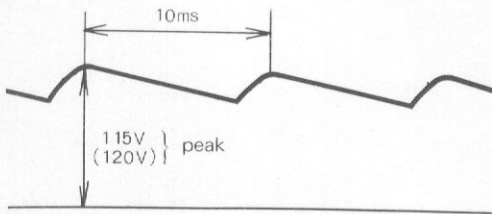

Fig. 42

CAPACITORS

Symbol	Description			Part No.
C901	Electrolytic	3.3	350V	RCH-029
C902	Electrolytic	47	35V	CEA 470P 35
C903	Electrolytic	33	25V	CEA 330P 25
C904	Electrolytic	0.47	50V	CEA 0R47P 50
C905	Electrolytic	10	16V	CEA 100P 16
C906	Electrolytic	33	16V	CEA 330P 16
C907	Electrolytic	10	16V	CEA 100P 16
C908	Electrolytic	2.2	50V	RCH-032
C909	Electrolytic	0.1	25V	CSSA 0R1M 25
C910	Electrolytic	0.1	25V	CSSA 0R1M 25
C911	Electrolytic	0.1	25V	CSSA 0R1M 25
C912	Electrolytic	4.7	25V	RCG-033
C913	Mylar	0.01	50V	CQMA 103K 50
C914	Electrolytic	4.7	25V	RCH-033
C915	Mylar	0.0047	50V	CQMA 472K 50
C916	Mylar	0.022	50V	CQMA 223K 50
C917	Styrol	0.0075	50V	RCE-027
C918	Electrolytic	2.2	50V	RCH-032
C919	Electrolytic	2.2	50V	RCH-032
C920	Mylar	0.0018	50V	CQMA 182K 50
C921	Metallized paper	2.5	250V	
C922	Metallized paper	6.8	125V	
CR901	Spark killer			RWX-030
CR902	Spark killer			RWX-030
CR903	Spark killer			RWX-030
CR904	Spark killer			RWX-030

RESISTORS

Symbol	Description			Part No.
VR901	Semi-fixed	1K-B		RCP-036
VR902	Semi-fixed	2K-B		RCP-034
VR903	Semi-fixed	2K-B		RCP-034
VR904	Semi-fixed	10K-B		RCP-035
R901	Carbon film	100	1/2W	RD1/4PSF 101K
R902	Carbon film	10k		RD1/4PSF 103K
R903	Carbon film	1.2k		RD1/4PS 122J
R904	Carbon film	5.6k		RD1/4PS 562J
R905	Carbon film	5.6k		RD1/4PS 562J
R906	Carbon film	1k		RD1/4PS 102J
R907	Carbon film	220		RD1/4PS 221J
R908	Carbon film	2.2k		RD1/4PS 222J
R909	Carbon film	33k		RD1/4PS 333J
R910	Carbon film	47k		RD1/4PS 473J
R911	Carbon film	27k		RD1/4PS 273J
R912	Carbon film	1.5k		RD1/4PS 152J

**13.18 SWITCH ASSEMBLY (RWS-058 KC type)
(RWS-059 KU type)**

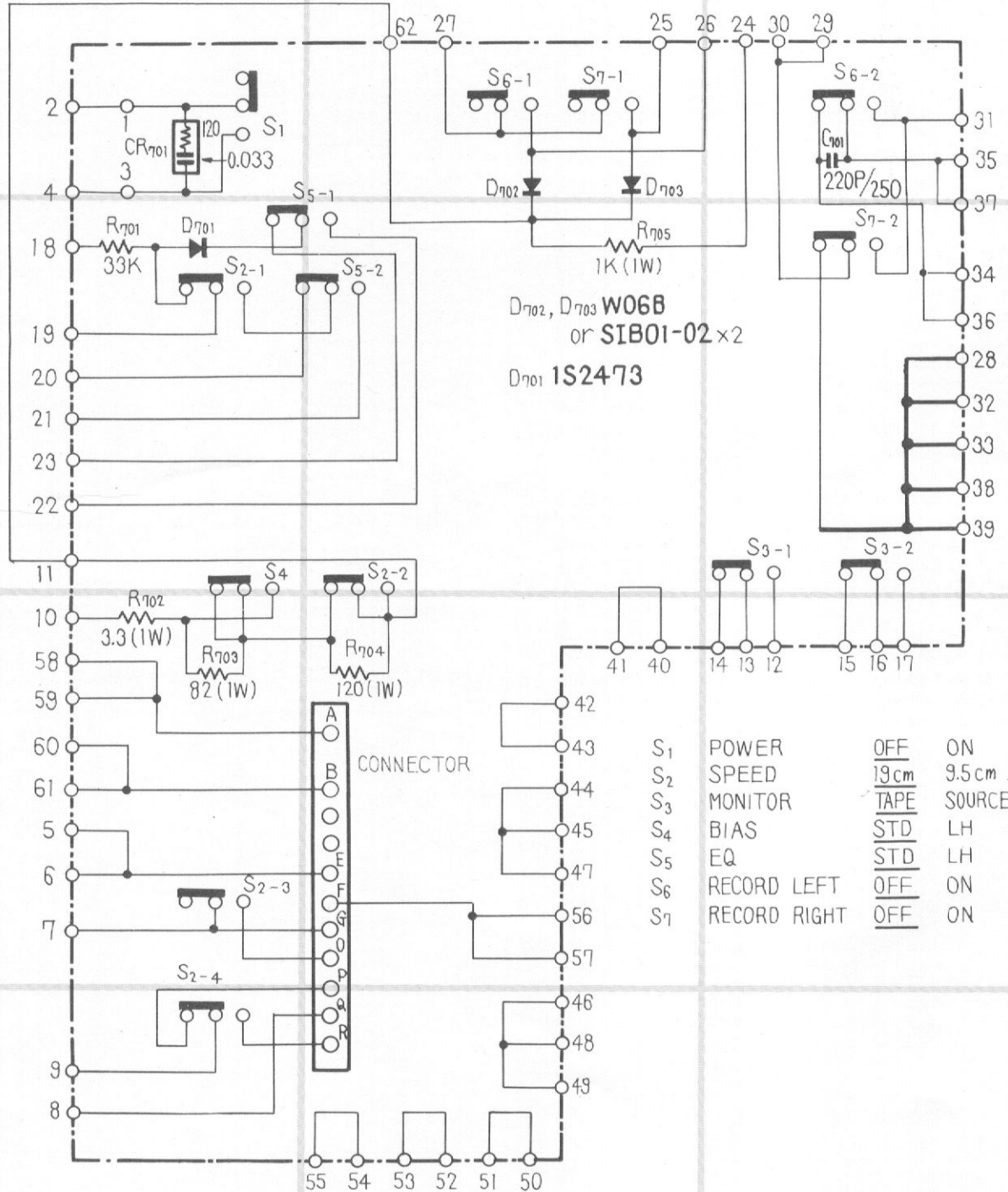

D702, D703 **W06B**
or **SIB01-02 x 2**
D701 **1S2473**

S1	POWER	<u>OFF</u>	ON
S2	SPEED	<u>19cm</u>	9.5cm
S3	MONITOR	<u>TAPE</u>	SOURCE
S4	BIAS	<u>STD</u>	LH
S5	EQ	<u>STD</u>	LH
S6	RECORD LEFT	<u>OFF</u>	ON
S7	RECORD RIGHT	<u>OFF</u>	ON

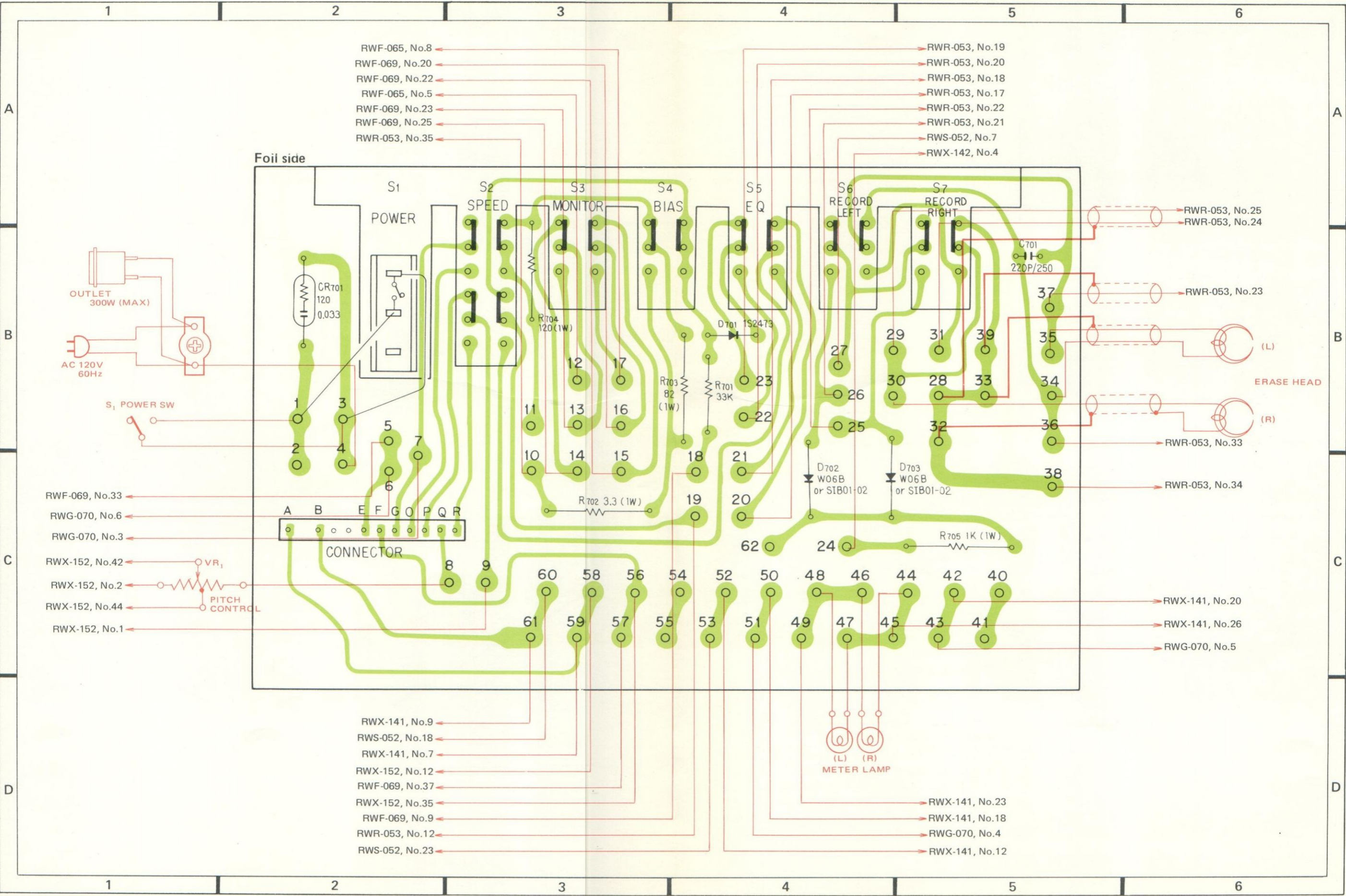

14. PACKING

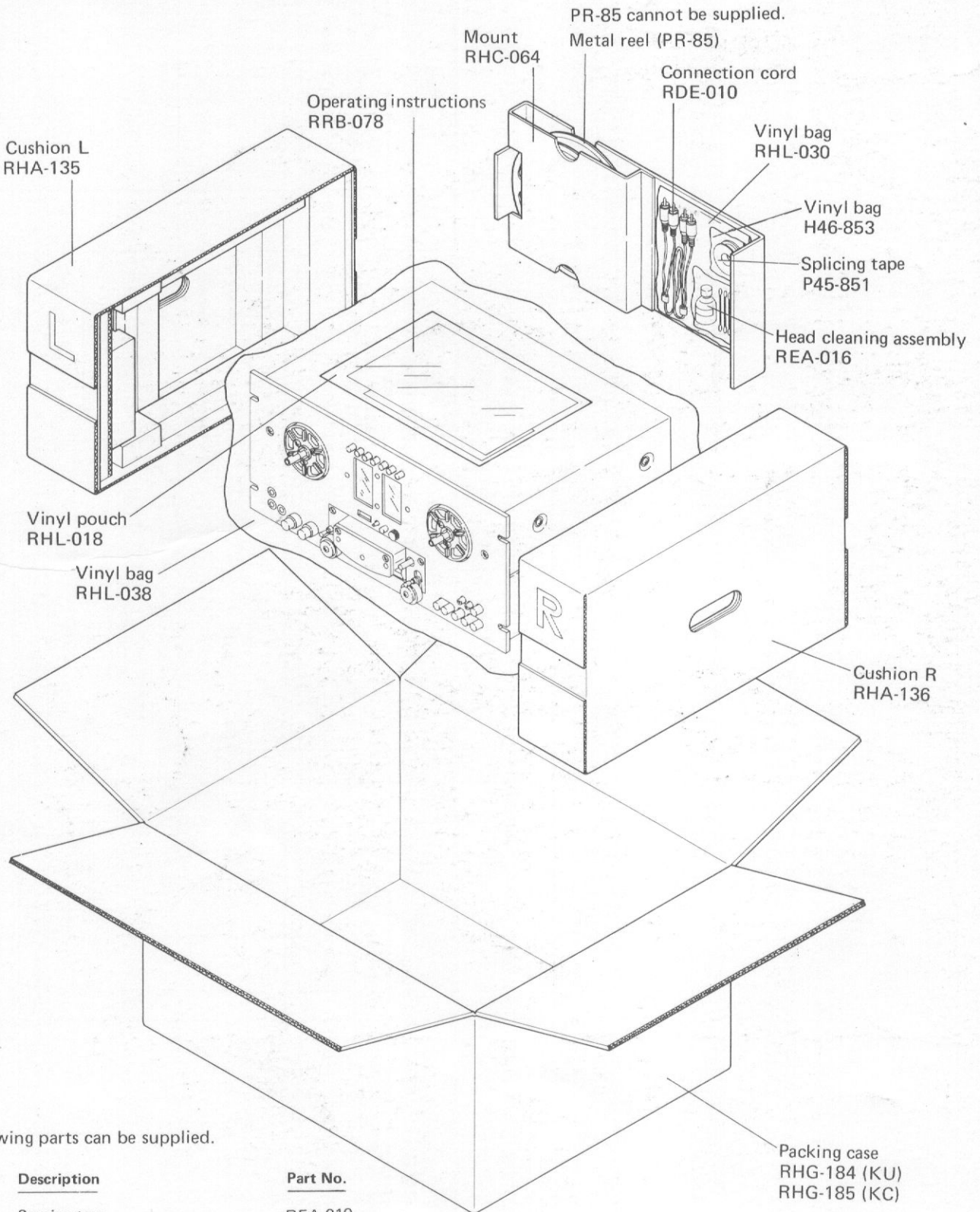

The following parts can be supplied.

<u>Symbol</u>	<u>Description</u>	<u>Part No.</u>
	Sensing tape	REA-019
	Reel pad	REB-210
	Reel pad instructions	RRF-040